



# SMART BAND® & SMART TIE™

*Technical Booklet*



J A N U A R Y 2 0 1 2





## Technical Information

Below is the index for HCL Clamping Solutions' Smart Band® and Smart Tie™ Technical Booklet. Through many years of experience in the manufacture of Smart Band®, Smart Tie™ and other plastic clamping solutions, HCL has built up extensive supplier relationships and knowledge of in-depth technical information. Should you require any information outside of the scope of this booklet, please contact HCL directly.



### Technical

---

1.1 | Dimensions & Weights

### Installation

---

2.1 | Design Guidelines

2.2 | Fitting Tool Overview

2.3 | Tool Tightening Forces

### Performance

---

3.1 | Straight Band Tensile

3.2 | System Tensile

3.3 | Effect of Moisture on Tensile Strength

3.4 | System Creep

3.5 | Impact Resistance

3.6 | Piggyback Pipe Lay

3.7 | Half Shell Minimum Bending Radius

3.8 | Hydrostatic Compression

### Material

---

4.1 | Abrasion

4.2 | Marine Growth

4.3 | Temperature Resistance

4.4 | Material Properties

4.5 | Offshore/Subsea Environments

4.6 | Weathering

4.7 | Chemical Resistance

### Quality

---

5.1 | Quality Procedure

## 1.1 | Dimensions & Weights

### 1.1.1 | Smart Tie™

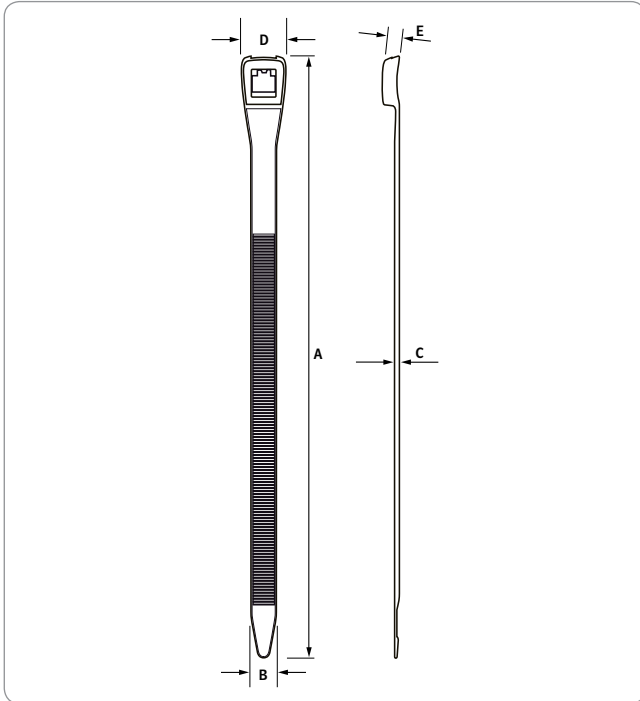

Dimensions Table

Size	Maximum Length (A)		Band Width (B)		Band Thickness (C)		Head Width (D)		Head Height (E)	
	mm	inch	mm	inch	mm	inch	mm	inch	mm	inch
750	770.0	30.31	20.0	0.79	3.6	0.14	35.0	1.38	12.0	0.47

Weight & Density Table

Size	Material	Weight/Length		Density Average	
		g/m	oz/ft	g/cm <sup>3</sup>	oz/inch <sup>3</sup>
750	PA66 (Nylon 6.6.)	60	2.11	1.15	0.66
	PA11 (Nylon 11)	52	1.85	1.04	0.60

### 1.1.2 | Smart Band® Band

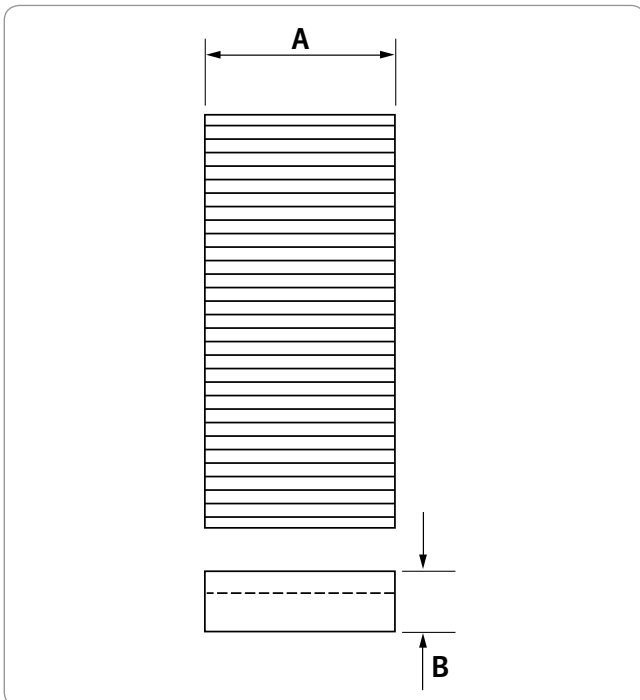

Dimensions Table

Size	Maximum Width (A)		Maximum Thickness (B)	
	mm	inch	mm	inch
7mm (¼")	6.9	0.27	2.6	0.10
10mm (⅜")	9.8	0.39	3.6	0.14
19mm (¾")	19.2	0.76	3.6	0.14
32mm (1¼")	32.2	1.27	4.7	0.19

Weight & Density Table

Size	Material	No. of Glass cords	Weight/Length		Density Average	
			g/m	oz/ft	g/cm <sup>3</sup>	oz/inch <sup>3</sup>
7mm (¼")	PA66 (Nylon 6.6.)	0	14	0.15	1.14	0.66
10mm (⅜")	PA66 (Nylon 6.6.)	2	30	0.32	1.15	0.66
19mm (¾")	PA66 (Nylon 6.6.)	11	70	0.75	1.23	0.71
	PA11GF (Nylon 11 Glass-filled)		72	0.77	1.26	0.73
	POM (Acetal)		84	0.90	1.48	0.86
32mm (1¼")	PA11GF (Nylon 11 Glass-filled)	21	151	1.62	1.21	0.70
	POM (Acetal)		164	1.76	1.33	0.77

## 1.1 | Dimensions & Weights

### 1.1.3 | Smart Band® Standard Buckles

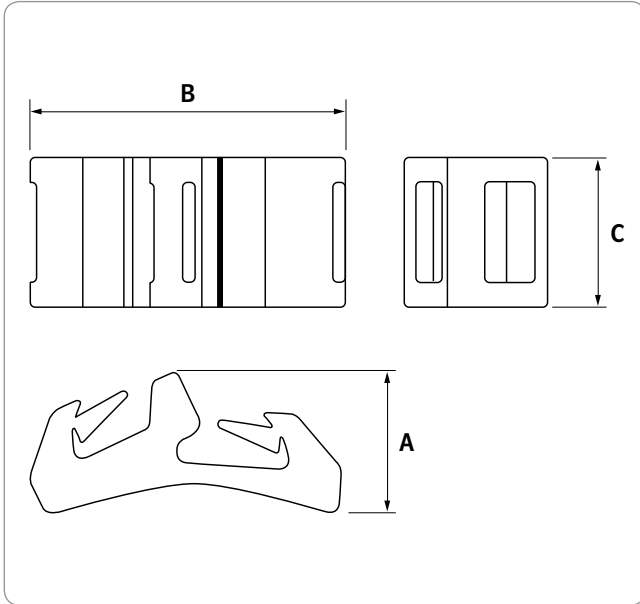

Dimensions Table

Size	Maximum Height (A)		Maximum Length (B)		Maximum Width (C)	
	mm	inch	mm	inch	mm	inch
7mm (¼")	19.2	0.76	76.0	2.99	15.1	0.59
10mm (⅜")	21.5	0.85	77.2	3.04	22.9	0.90
19mm (¾")	28.3	1.11	63.8	2.51	30.2	1.19

Weight & Density Table

Size	Material	Weight		Density Average	
		g	oz	g/cm³	oz/inch³
7mm (¼")	PA66 (Nylon 6.6.)	7	0.24	1.14	0.66
10mm (⅜")	PA66 (Nylon 6.6.)	12	0.41	1.14	0.66
19mm (¾")	PA66 (Nylon 6.6.)	24	0.86	1.14	0.66

### 1.1.4 | Smart Band® Hybrid Buckles

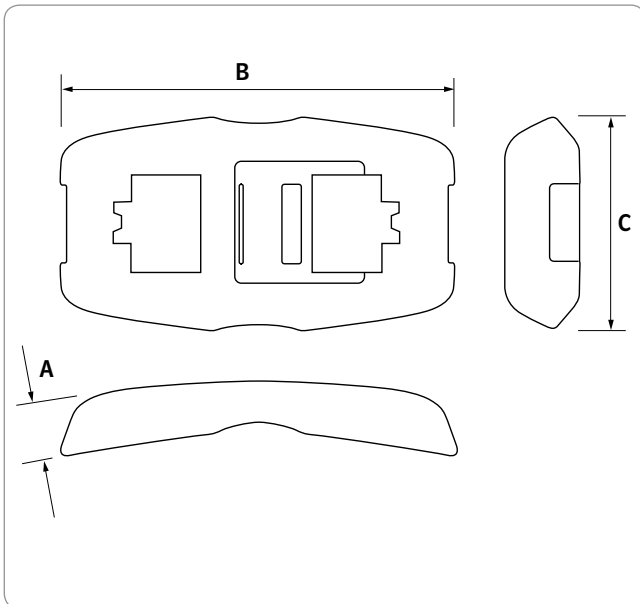

Dimensions Table

Size	Maximum Height (A)		Maximum Length (B)		Maximum Width (C)	
	mm	inch	mm	inch	mm	inch
19mm (¾")	12.8	0.50	99.0	3.90	53.0	2.09
32mm (1¼")	16.8	0.66	135.5	5.33	76.8	3.02

Weight & Density Table

Size	Material	Weight		Density Average	
		g	oz	g/cm³	oz/inch³
19mm (¾")	PA66 (Nylon 6.6.)	36	1.27	1.20	0.70
	PA11GF (Nylon 11 Glass-filled)	39	1.38	1.30	0.75
	POM (Acetal)	41	1.45	1.37	0.79
32mm (1¼")	PA11GF (Nylon 11 Glass-filled)	96	3.39	1.29	0.75
	POM (Acetal)	101	3.57	1.36	0.78

# INSTALLATION

## 2.1 | Design Guidelines

The following design guidelines for applications utilising Smart Tie™ or Smart Band® will ensure maximum performance of the banding product. The underside of the buckles are curved, so it is recommended that the radius on the application is designed to match the radius on the buckle whenever possible. For environments prone to abrasion or impact, it is recommended that the Smart Band® is recessed into the application, in order to give the product greater protection. Certain applications, particularly smaller diameters, may require a special area to be created for the buckle, as shown below.

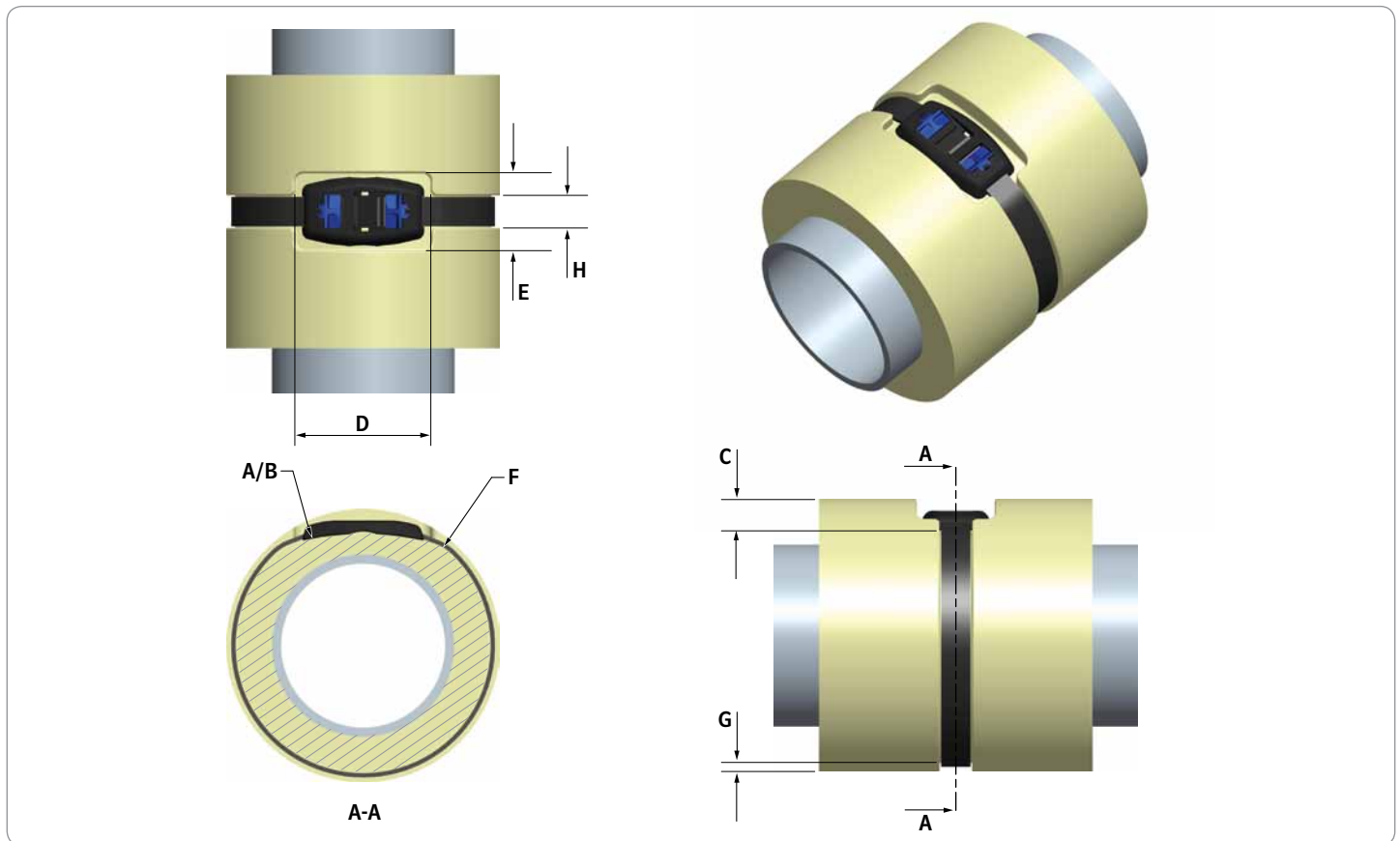

### 2.1.1 | Buckle Recess Dimensions

Product	Size	Recommended Buckle Radius (A)		Minimum Buckle Radius (B)		Minimum Recess Depth (C)		Minimum Recess Length (D)		Minimum Recess Width (E)	
		mm	inch	mm	inch	mm	inch	mm	inch	mm	inch
Smart Tie™	20mm (¾")	100	3.94	75	2.95	13	0.51	50	1.97	39	1.54
Smart Band® Standard	7mm (¼")	300	11.81	50	1.97	21	0.83	86	3.39	19	0.75
	10mm (⅜")	300	11.81	38	1.48	23	0.91	88	3.46	27	1.06
	19mm (¾")	100	3.94	38	1.48	30	1.18	75	2.95	34	1.34
Smart Band® Hybrid	19mm (¾")	200	7.87	100	3.94	14	0.55	110	4.33	57	2.24
	32mm (1¼")	300	11.81	200	7.87	18	0.71	145	5.71	81	3.19

### 2.1.2 | Band Recess Dimensions

Product	Size	Minimum Band Radius (F)		Minimum Recess Depth (G)		Minimum Recess Width (H)	
		mm	inch	mm	inch	mm	inch
Smart Tie™	20mm (¾")	10	0.39	5	0.20	22	0.87
Smart Band®	7mm (¼")			4	0.16	9	0.35
	10mm (⅜")			5	0.20	12	0.47
	19mm (¾")			5	0.20	22	0.87
	32mm (1¼")			6	0.24	36	1.42

### 2.1.3 | General points for design consideration are as follows:

- 1 Ideally, the Smart Band® or Smart Tie™ buckle should be positioned on a radius; please see the opposite page for recommendations. If the buckle must be positioned on a diameter smaller than is recommended, then the banding product may require installation at a reduced tension and the system strength should be expected to be lower than the published values.
- 2 If it is not possible for the buckle to be positioned on a suitable radius, then the buckle should be positioned on a flat surface. If positioning the buckle on a flat surface, avoid sharp corners near to the buckle (see bottom of this page); it may also be necessary to reduce the installation tension, and the system strength should be expected to be lower than the published values.
- 3 Where possible, avoid suspending the buckle in mid-air. If this is unavoidable, then the banding product may require installation at a reduced tension and the system strength should be expected to be lower than the published values.

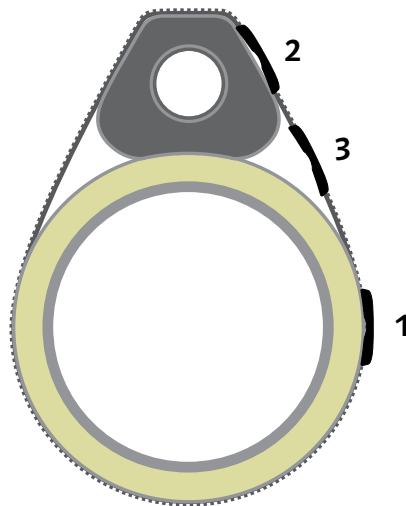

- Where possible, avoid having a sharp band radius near to the end of the buckle. If this is necessary, e.g. on a smaller diameter application, then the recess length for the buckle (dimension 'D' on the opposite page) should be increased in order to move the sharp band radius away from the buckle. If this is unavoidable, then the banding product may require installation at a reduced tension and the system strength should be expected to be lower than the published values.

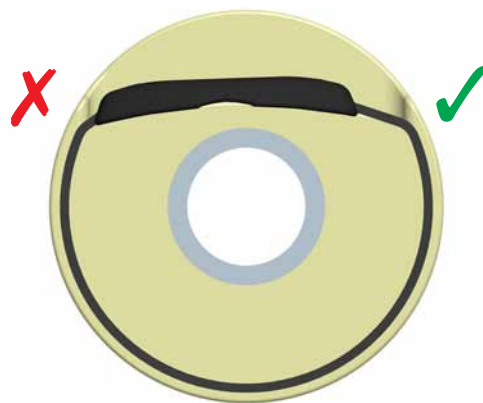

## 2.2 | Fitting Tool Overview



**Smart Band® Standard, 7 - 10mm width - Tensioning & Cutting Tool**

PART NUMBER	<b>SM-TA-528A</b>
DIMENSIONS	<b>215x130x30mm</b>
WEIGHT	<b>0.43kg</b>
BOX QUANTITY	<b>1</b>

This lightweight ergonomic tool is designed for single-handed operation, both tightening and cutting the 7mm (¼") and 10mm (⅜") Smart Band® sizes.



**Smart Tie™ & Smart Band® 19mm - Tensioning & Cutting Tool**

PART NUMBER	<b>SM-FT-2000-19</b>
DIMENSIONS	<b>370x285x55mm</b>
WEIGHT	<b>0.75kg</b>
BOX QUANTITY	<b>1</b>

Incorporating both tensioning and cutting mechanisms; this tool is fully corrosion resistant, lightweight, ergonomic and easy to use, ensuring that the 19mm (¾") Smart Band® and the 20mm (¾") Smart Tie™ can be fitted quickly and efficiently.



**Smart Band® 19mm or 32mm - Tensioning & Cutting Tool**

PART NUMBER	<b>SM-FT-1000-19 or SM-FT-1000-32</b>
DIMENSIONS	<b>410x255x135mm</b>
WEIGHT	<b>2.79kg</b>
BOX QUANTITY	<b>1</b>

This fully corrosion resistant manual tool can accurately tension the 19mm (¾") or 32mm (1¼") Smart Band® (with the use of a torque wrench), as well as trim the excess band following tightening.



**Band Cutters**

PART NUMBER	<b>MT-C-01</b>
DIMENSIONS	<b>250x75x30mm</b>
WEIGHT	<b>0.39kg</b>
BOX QUANTITY	<b>1</b>

Whether cutting the Smart Band® to length, or trimming the excess band following tightening; these ergonomic cutters provide excellent savings in both time and effort.



**Smart Band® 19mm or 32mm, Air Ratchet - Tensioning & Cutting Tool**

PART NUMBER	<b>SM-FT-1000-PR-19 or SM-FT-1000-PR-32</b>
DIMENSIONS	<b>450x300x135mm</b>
WEIGHT	<b>4.00kg</b>
BOX QUANTITY	<b>1</b>

This pneumatic tool provides a faster, easier method of tensioning the Smart Band® than HCL's manual tools (accurate tensioning can be achieved through the additional use of a torque wrench). The tool can also trim the excess band following tightening.



**Smart Band® 19mm or 32mm, Air Shut-off Driver - Tensioning & Cutting Tool**

PART NUMBER	<b>SM-FT-1000-PS-19 or SM-FT-1000-PS-32</b>
DIMENSIONS	<b>475x450x135mm</b>
WEIGHT	<b>6.80kg</b>
BOX QUANTITY	<b>1</b>

HCL's premium pneumatic tool provides excellent tensioning speed, accuracy and repeatability through the use of a pneumatic torque shut-off driver. The tool can also trim the excess band following tightening.

# INSTALLATION

## 2.3 | Tool Tightening Forces

### SM-TA-528A

Product	Size	Buckle Material	Band Material	Maximum System Force (During Tightening)			Minimum Retention Force (After Tightening)		
				N	kgf	lbf	N	kgf	lbf
Smart Band* Standard	7mm (¼")	PA66 (Nylon 6.6.)	PA66 (Nylon 6.6.)	400	41	90	200	20	45
	10mm (⅜")	PA66 (Nylon 6.6.)	PA66 (Nylon 6.6.)	1800	184	405	750	77	169

### SM-FT-2000

Product	Size	Buckle Material	Band Material	Maximum System Force (During Tightening)			Minimum Retention Force (After Tightening)		
				N	kgf	lbf	N	kgf	lbf
Smart Tie™	20mm (¾")	PA66 (Nylon 6.6.)	PA66 (Nylon 6.6.)	3000	306	674	1800	184	405
		PA11 (Nylon 11)	PA11 (Nylon 11)	3000	306	674	1800	184	405
Smart Band* Standard	19mm (¾")	PA66 (Nylon 6.6.)	PA66 (Nylon 6.6.)	4000	408	899	1200	122	270
		PA66 (Nylon 6.6.)	POM (Acetal)	3600	367	809	1200	122	270
Smart Band* Hybrid	19mm (¾")	PA66 (Nylon 6.6.)	PA66 (Nylon 6.6.)	4500	459	1012	2000	204	450
		PA11GF (Nylon 11 Glass-filled)	PA11GF (Nylon 11 Glass-filled)	4500	459	1012	2000	204	450
		POM (Acetal)	POM (Acetal)	4500	459	1012	2000	204	450

### SM-FT-1000 with Torque Wrench

Product	Size	Buckle Material	Band Material	Maximum System Force (During Tightening)			Minimum Retention Force (After Tightening)		
				N	kgf	lbf	N	kgf	lbf
Smart Tie™	20mm (¾")	PA66 (Nylon 6.6.)	PA66 (Nylon 6.6.)	3300	337	742	2000	204	450
		PA11 (Nylon 11)	PA11 (Nylon 11)	2800	286	629	1400	143	315
Smart Band* Standard	19mm (¾")	PA66 (Nylon 6.6.)	PA66 (Nylon 6.6.)	3500	357	787	1200	122	270
		PA66 (Nylon 6.6.)	POM (Acetal)	3500	357	787	1200	122	270
Smart Band* Hybrid	19mm (¾")	PA66 (Nylon 6.6.)	PA66 (Nylon 6.6.)	6500	663	1461	3500	357	787
		PA11GF (Nylon 11 Glass-filled)	PA11GF (Nylon 11 Glass-filled)	7000	714	1574	3500	357	787
		POM (Acetal)	POM (Acetal)	6000	612	1349	2500	255	562
	32mm (1¼")	PA11GF (Nylon 11 Glass-filled)	PA11GF (Nylon 11 Glass-filled)	14000	1428	3147	7000	714	1574
		POM (Acetal)	POM (Acetal)	10000	1020	2248	6000	612	1349

### SM-FT-1000 with Air Ratchet

Product	Size	Buckle Material	Band Material	Maximum System Force (During Tightening)			Minimum Retention Force (After Tightening)		
				N	kgf	lbf	N	kgf	lbf
Smart Tie™	20mm (¾")	PA66 (Nylon 6.6.)	PA66 (Nylon 6.6.)	3500	357	787	1500	153	337
		PA11 (Nylon 11)	PA11 (Nylon 11)	3200	326	719	1400	143	315
Smart Band* Standard	19mm (¾")	PA66 (Nylon 6.6.)	PA66 (Nylon 6.6.)	3000	306	674	1100	112	247
		PA66 (Nylon 6.6.)	POM (Acetal)	3000	306	674	1100	112	247
Smart Band* Hybrid	19mm (¾")	PA66 (Nylon 6.6.)	PA66 (Nylon 6.6.)	6500	663	1461	3500	357	787
		PA11GF (Nylon 11 Glass-filled)	PA11GF (Nylon 11 Glass-filled)	7000	714	1574	3500	357	787
		POM (Acetal)	POM (Acetal)	5500	561	1236	2500	255	562
	32mm (1¼")	PA11GF (Nylon 11 Glass-filled)	PA11GF (Nylon 11 Glass-filled)	14500	1479	3260	7000	714	1574
		POM (Acetal)	POM (Acetal)	10000	1020	2248	5000	510	1124

### SM-FT-1000 with Torque Shut-off Tool

Product	Size	Buckle Material	Band Material	Maximum System Force (During Tightening)			Minimum Retention Force (After Tightening)		
				N	kgf	lbf	N	kgf	lbf
Smart Band* Hybrid	19mm (¾")	PA11GF (Nylon 11 Glass-filled)	PA11GF (Nylon 11 Glass-filled)	8000	816	1798	3800	388	854
	32mm (1¼")	PA11GF (Nylon 11 Glass-filled)	PA11GF (Nylon 11 Glass-filled)	16000	1632	3597	9000	918	2023

Final Retention Force may be slightly lower on very small diameters.

Final Retention Force will be significantly higher on very large diameters.

## 3.1 | Straight Band Tensile

### 3.1.1 | Introduction

Test pre-load: 200N  
 Test Speed: 5mm/min  
 Specimen Length: 200mm (7.9")  
 Specimen Condition: 23°C at 50% RH



### 3.1.2 | Effective Band Dimensions (ignoring teeth)

Size	Width		Thickness	
	mm	inch	mm	inch
7mm (¼")	6.9	0.27	1.6	0.06
10mm (⅜")	9.8	0.39	2.4	0.09
19mm (¾")	19.2	0.76	2.4	0.09
32mm (1¼")	32.2	1.27	3.1	0.12

### 3.1.3 | Straight Band Results Table Overview

Banding Product	Band Size	Band Material	Break Strength			Break Strain
			N	kgf	lbf	%
Smart Band®	7mm (¼")	PA66 (Nylon 6.6.)	400	41	90	163.5
	10mm (⅜")	PA66 (Nylon 6.6.)	2020	206	454	3.5
	19mm (¾")	PA66 (Nylon 6.6.)	9890	1009	2223	4.4
		PA11GF (Nylon 11 Glass-filled)	11470	1170	2578	4.7
		POM (Acetal)	8880	906	1996	5.3
	32mm (1¼")	PA11GF (Nylon 11 Glass-filled)	20730	2114	4660	6.1
		POM (Acetal)	18650	1902	4193	6.4

## 3.1 | Straight Band Tensile

### 3.1.4 | Smart Tie™

Line No	Band Size	Band Material	Tensile Strength			Strain
			N	kgf	lbf	%
1	20mm (¾")	PA66 (Nylon 6.6.)	2420 <sup>1</sup>	247 <sup>1</sup>	544 <sup>1</sup>	121.3 <sup>1</sup>
2		PA11 (Nylon 11)	1641 <sup>2</sup>	167 <sup>2</sup>	369 <sup>2</sup>	21.2 <sup>2</sup>

<sup>1</sup> Tensile strength and strain recorded at Break

<sup>2</sup> Tensile strength and strain recorded at Yield

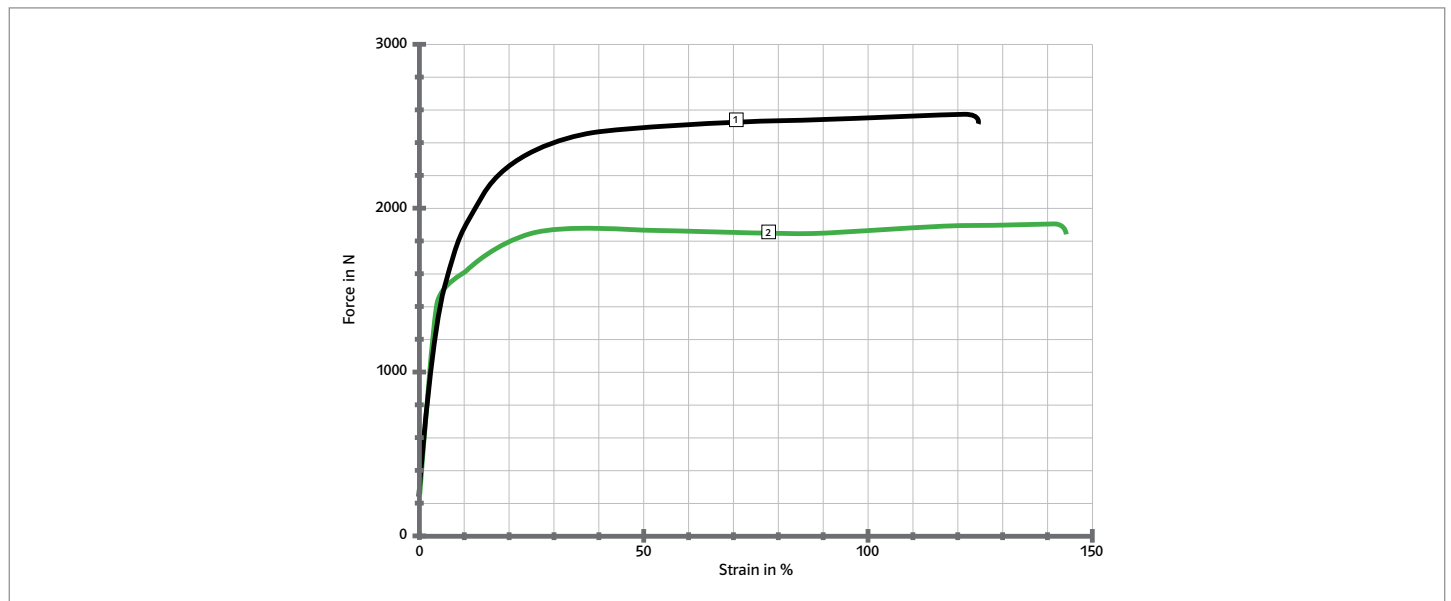

### 3.1.5 | Smart Band® - 7 & 10mm

Line No	Band Size	Band Material	Break Strength			Break Strain
			N	kgf	lbf	%
1	7mm (¼")	PA66 (Nylon 6.6.)	400	41	90	163.5
2	10mm (⅜")	PA66 (Nylon 6.6.)	2020	206	454	3.5

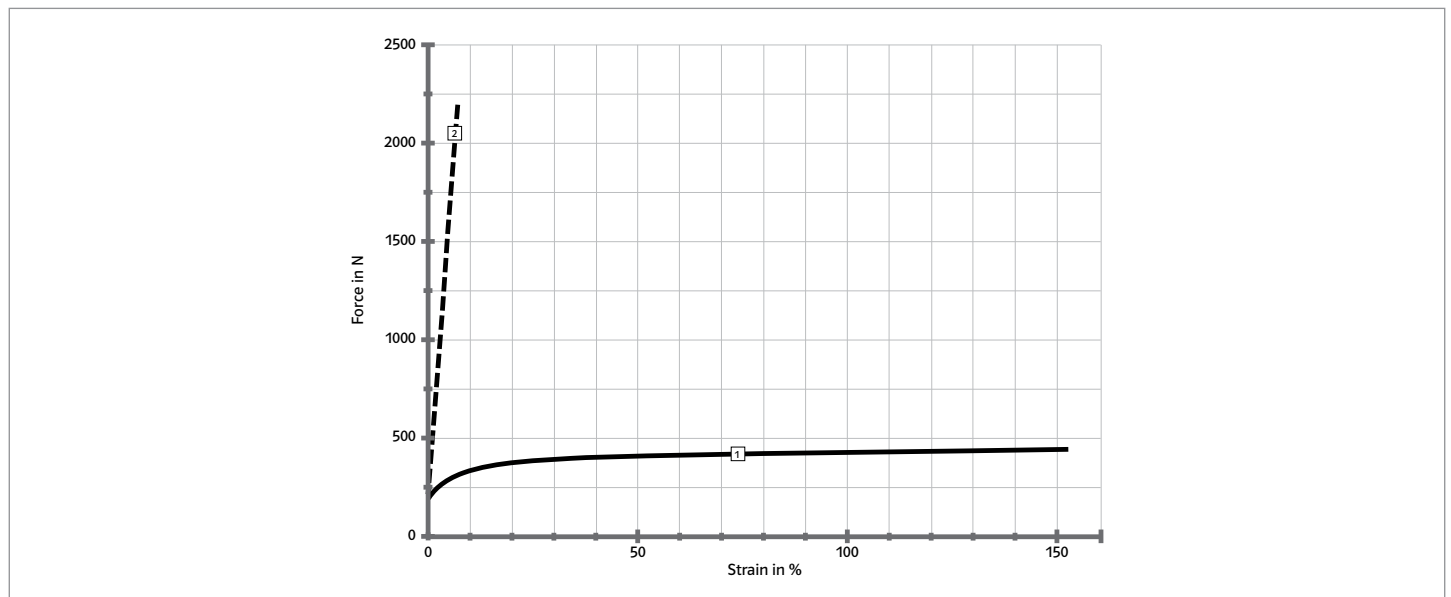

## 3.1 | Straight Band Tensile

### 3.1.6 | Smart Band® - 19mm

Line No	Band Size	Band Material	Break Strength			Break Strain
			N	kgf	lbf	%
1	19mm (¾")	PA66 (Nylon 6.6.)	9890	1009	2223	4.4
2		PA11GF (Nylon 11 Glass-filled)	11470	1170	2578	4.7
3		POM (Acetal)	8880	906	1996	5.3

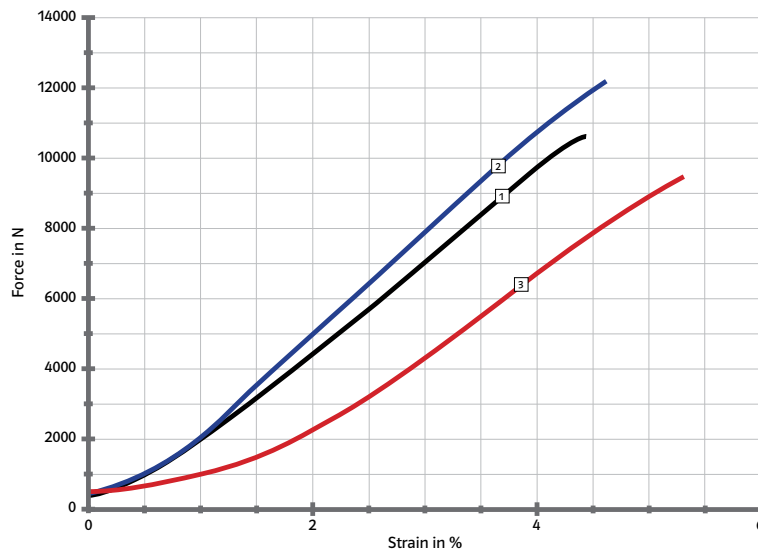

### 3.1.7 | Smart Band® - 32mm

Line No	Band Size	Band Material	Break Strength			Break Strain
			N	kgf	lbf	%
1	32mm (1¼")	PA11GF (Nylon 11 Glass-filled)	20730	2114	4660	6.1
2		POM (Acetal)	18650	1902	4193	6.4

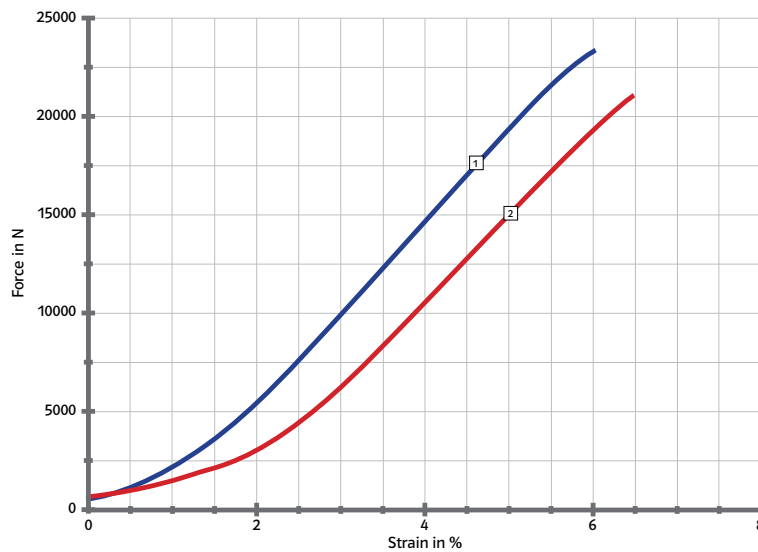

## 3.2 | System Tensile

### 3.2.1 | Introduction

Test Fixture:	2x Steel half-shells
Test pre-load:	200N
Test Speed:	5mm/min (10mm/min Effective circumferential speed)
Specimen Length:	As per 'System Test Diameter and Circumference Table' below
Specimen Condition:	23°C at 50% RH

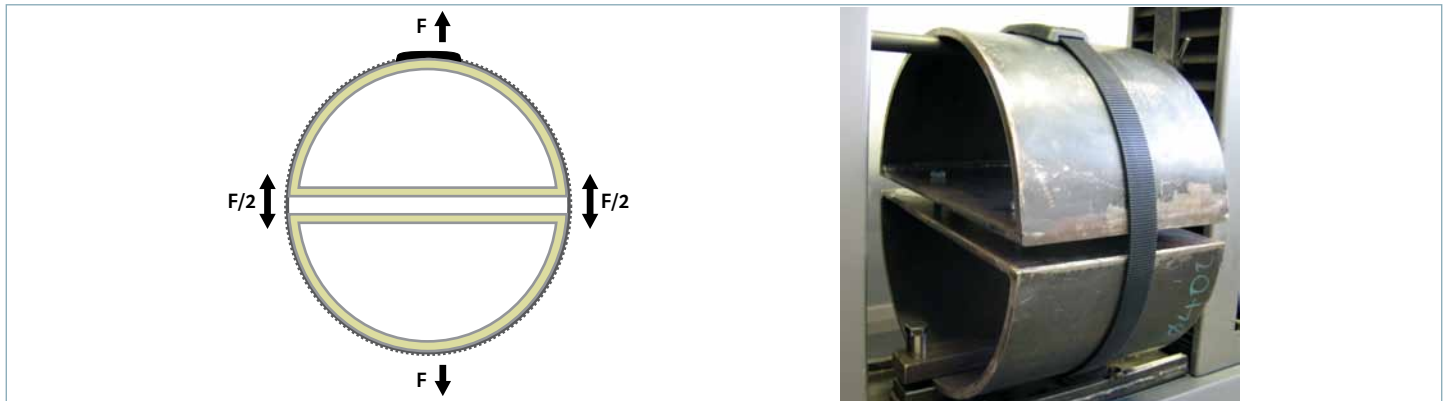

### 3.2.2 | Effective Band Dimensions (ignoring teeth)

Size	Width		Thickness	
	mm	inch	mm	inch
7mm (¼")	6.9	0.27	1.6	0.06
10mm (⅜")	9.8	0.39	2.4	0.09
19mm (¾")	19.2	0.76	2.4	0.09
32mm (1¼")	32.2	1.27	3.1	0.12

### 3.2.3 | System Test Diameter and Circumference Table

Test		Test Circumference	
mm	inch	mm	inch
100	3.9	330	13.0
200	7.9	650	25.6
280	11.0	910	35.8
400	15.7	1300	51.2
600	23.6	1950	76.8
800	31.5	2600	102.4

### 3.2.4 | Smart Band® System Test Overview

Banding Product	Size	Buckle Material	Band Material	Test Diameter <sup>1</sup>	Break Strength			Circumferential Break Strain
				mm	N	kgf	lbf	%
Smart Band® Standard	7mm (¼")	PA66 (Nylon 6.6.)	PA66 (Nylon 6.6.)	100	880	90	198	65.9
	10mm (⅜")	PA66 (Nylon 6.6.)	PA66 (Nylon 6.6.)	600	2590	264	582	1.7
		PA66 (Nylon 6.6.)	PA66 (Nylon 6.6.)	600	4310	440	969	0.9
	19mm (¾")	PA66 (Nylon 6.6.)	POM (Acetal)	600	4100	418	922	1.5
PA66 (Nylon 6.6.)		PA66 (Nylon 6.6.)	600	13430	1370	3019	2.0	
Smart Band® Hybrid	19mm (¾")	PA11GF (Nylon 11 Glass-filled)	PA11GF (Nylon 11 Glass-filled)	600	12450	1270	2799	1.8
		POM (Acetal)	POM (Acetal)	600	9980	1018	2244	2.3
	32mm (1¼")	PA11GF (Nylon 11 Glass-filled)	PA11GF (Nylon 11 Glass-filled)	600	25010	2551	5622	2.3
		POM (Acetal)	POM (Acetal)	600	17200	1754	3867	2.5

<sup>1</sup> Test diameter quoted, which yielded the highest break strength

## 3.2 | System Tensile

### 3.2.5 | Smart Tie™

Line No	Band Size	Material	Test Diameter	System Yield Strength			Circumferential Yield Strain
			mm	N	kgf	lbf	%
1	20mm (¾")	PA66 (Nylon 6.6.)	100	5250	536	1180	18.0
2			200	5030	513	1131	18.7
3	20mm (¾")	PA11 (Nylon 11)	100	3920	400	881	14.8
4			200	4040	412	908	14.2

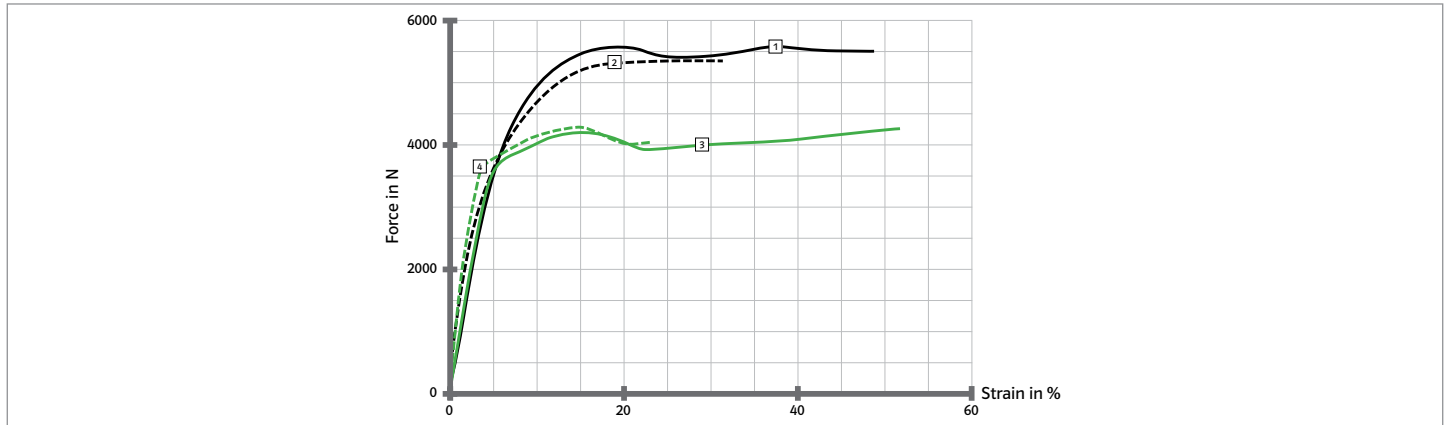

### 3.2.6 | Smart Band® 7mm Standard – PA66 (Nylon 6.6.)

Line No	Band Size	Material	Test Diameter	System Break Strength			Circumferential Break Strain
			mm	N	kgf	lbf	%
1	7mm (¼")	PA66 (Nylon 6.6.)	100	880	90	198	65.9
2			200	860	88	193	59.0
3			280	820	84	184	51.4
4			400	820	84	184	57.6

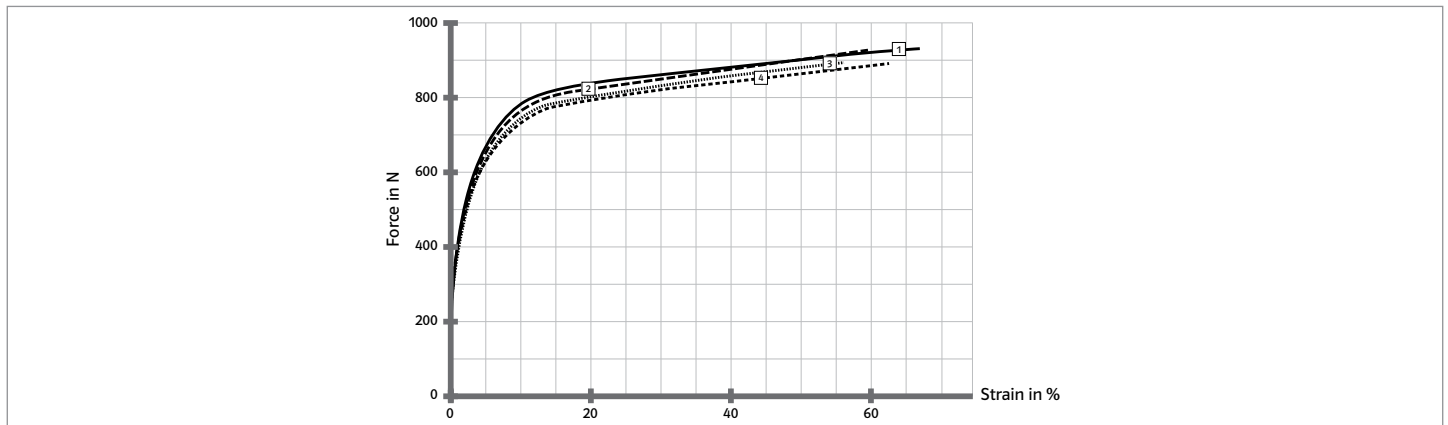

### Conclusion

- Results shown are for test specimens at 23°C and 50% Relative Humidity. PA66 (Nylon 6.6.) specimens at a higher humidity would be expected to be less stiff (lower Elastic Modulus), have a lower strength and a higher strain; conversely, PA66 (Nylon 6.6.) specimens at a lower humidity would be expected to be stiffer (higher Elastic Modulus), have a higher strength and a lower strain.

## 3.2 | System Tensile

### 3.2.7 | Smart Band® 10mm Standard – PA66 (Nylon 6.6.)

Line No	Band Size	Material	Test Diameter	System Break Strength			Circumferential Break Strain
			mm	N	kgf	lbf	%
1	10mm (3/8")	PA66 (Nylon 6.6.)	100	1761	180	396	3.3
2			200	2140	218	481	2.1
3			280	2140	218	481	1.8
4			400	2300	235	517	1.7
5			600	2590	264	582	1.7
6			800	2540	259	571	1.6

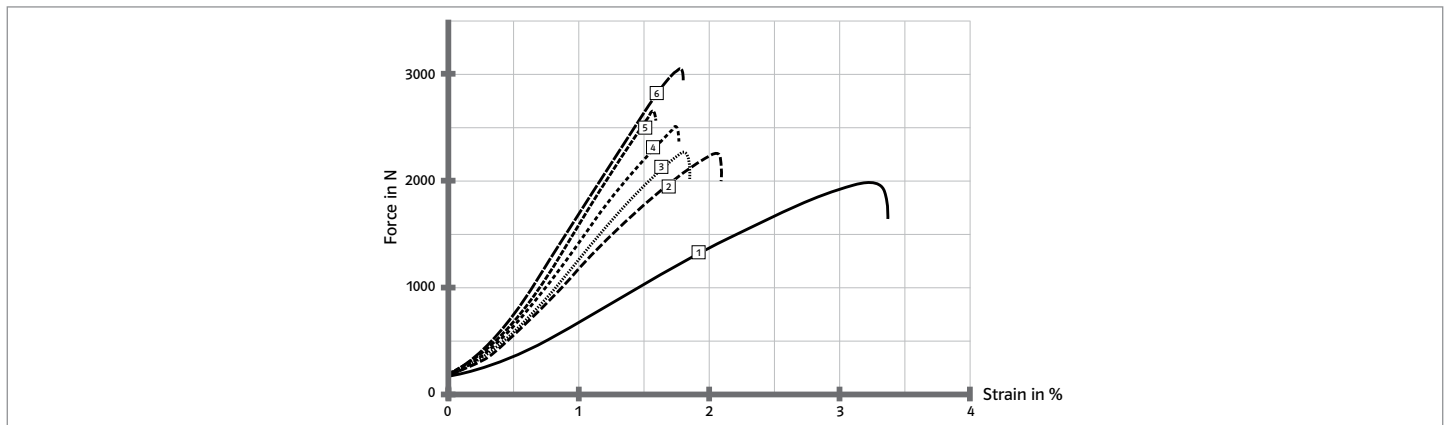

### 3.2.8 | Smart Band® 19mm Standard – PA66 (Nylon 6.6.)

Line No	Band Size	Buckle Material	Band Material	Test Diameter	System Break Strength			Circumferential Break Strain
				mm	N	kgf	lbf	%
1	19mm (3/4")	PA66 (Nylon 6.6.)	PA66 (Nylon 6.6.)	100	3400	347	764	3.6
2				200	3830	391	861	1.7
3				280	3590	366	807	1.2
4				400	4170	425	937	1.2
5				600	4310	440	969	0.9
6				800	3590	366	807	0.8

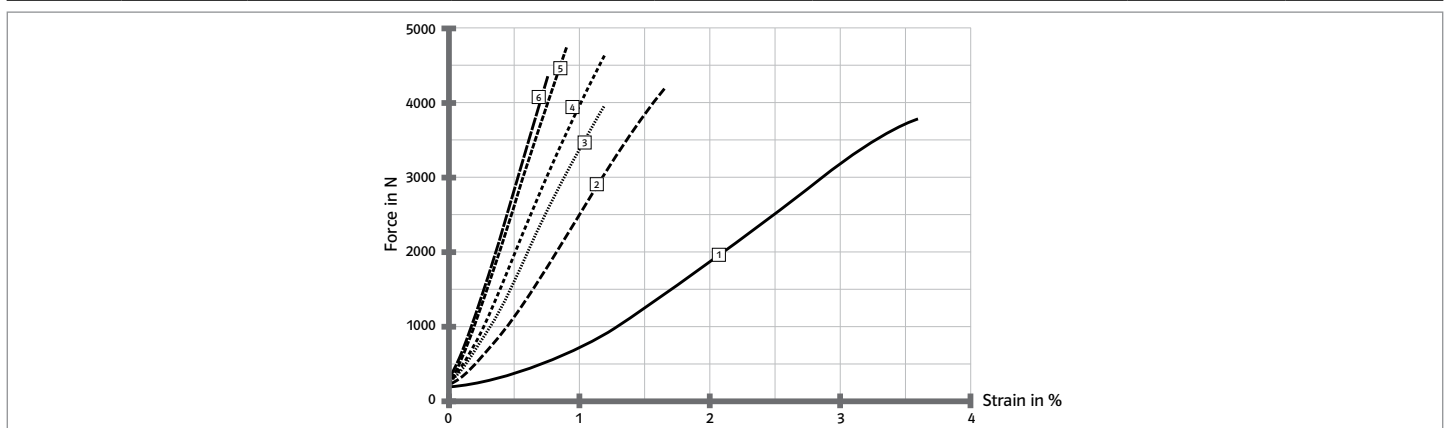

### Conclusion

- The Elastic Modulus (gradient of the curve) increases with the diameter. This is because the Smart Band® buckle bends and stretches further, the smaller the diameter.
- Results shown are for test specimens at 23°C and 50% Relative Humidity. PA66 (Nylon 6.6.) specimens at a higher humidity would be expected to be less stiff (lower Elastic Modulus), have a lower strength and a higher strain; conversely, PA66 (Nylon 6.6.) specimens at a lower humidity would be expected to be stiffer (higher Elastic Modulus), have a higher strength and a lower strain.

## 3.2 | System Tensile

### 3.2.9 | Smart Band® 19mm Standard – POM (Acetal)

Line No	Band Size	Buckle Material	Band Material	Test Diameter	System Break Strength			Circumferential Break Strain
				mm	N	kgf	lbf	%
1	19mm (¾")	PA66 (Nylon 6.6.)	POM (Acetal)	100	3380	345	760	4.0
2				200	3340	341	751	2.2
3				280	3750	383	843	1.7
4				400	3810	389	856	1.7
5				600	4100	418	922	1.5
6				800	3750	383	843	1.5

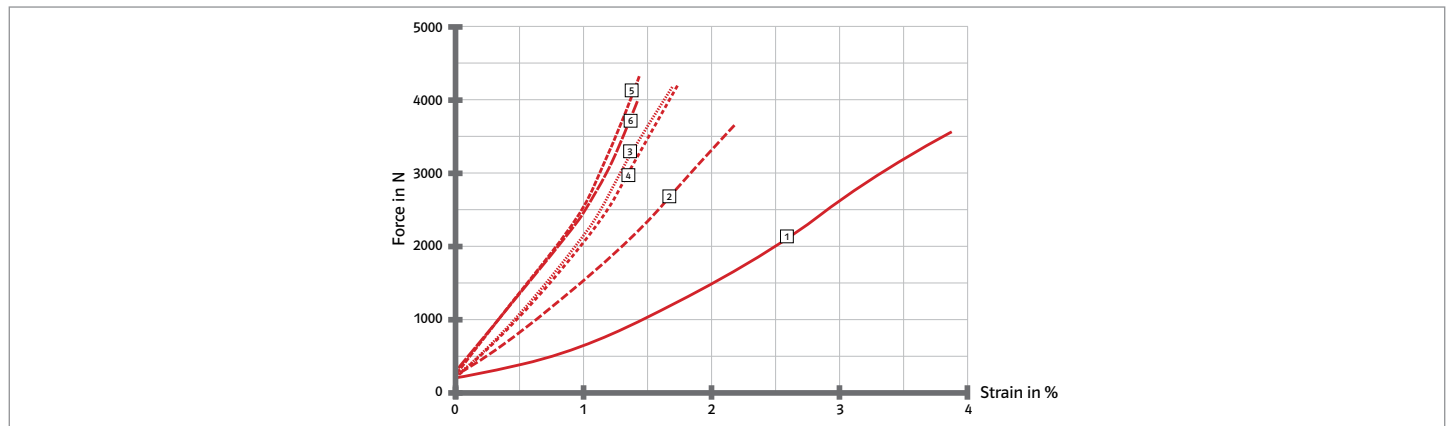

### 3.2.10 | Smart Band® 19mm Hybrid – PA66 (Nylon 6.6.)

Line No	Band Size	Material	Test Diameter	System Break Strength			Circumferential Break Strain
			mm	N	kgf	lbf	%
1	19mm (¾")	PA66 (Nylon 6.6.)	200	12570	1282	2826	3.7
2			280	13920	1420	3129	2.7
3			400	12250	1250	2754	2.2
4			600	13430	1370	3019	2.0
5			800	12100	1234	2720	1.7

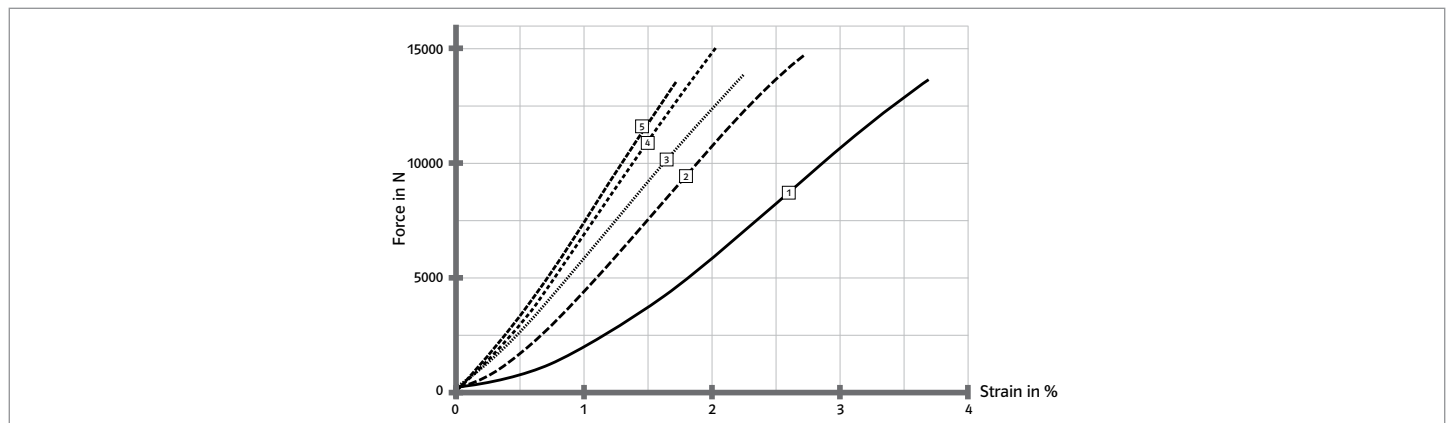

### Conclusion

- The Elastic Modulus (gradient of the curve) increases with the diameter. This is because the Smart Band® buckle bends and stretches further, the smaller the diameter.
- Results shown are for test specimens at 23°C and 50% Relative Humidity. **PA66 (Nylon 6.6.)** specimens at a higher humidity would be expected to be less stiff (lower Elastic Modulus), have a lower strength and a higher strain; conversely, **PA66 (Nylon 6.6.)** specimens at a lower humidity would be expected to be stiffer (higher Elastic Modulus), have a higher strength and a lower strain.

## 3.2 | System Tensile

### 3.2.11 | Smart Band® 19mm Hybrid – PA11GF (Nylon 11 Glass-filled)

Line No	Band Size	Material	Test Diameter	System Break Strength			Circumferential Break Strain
			mm	N	kgf	lbf	%
1	19mm (¾")	PA11GF (Nylon 11 Glass-filled)	200	11260	1149	2531	3.4
2			280	11200	1142	2518	2.3
3			400	11850	1209	2664	2.0
4			600	12450	1270	2799	1.8
5			800	12010	1225	2700	1.7

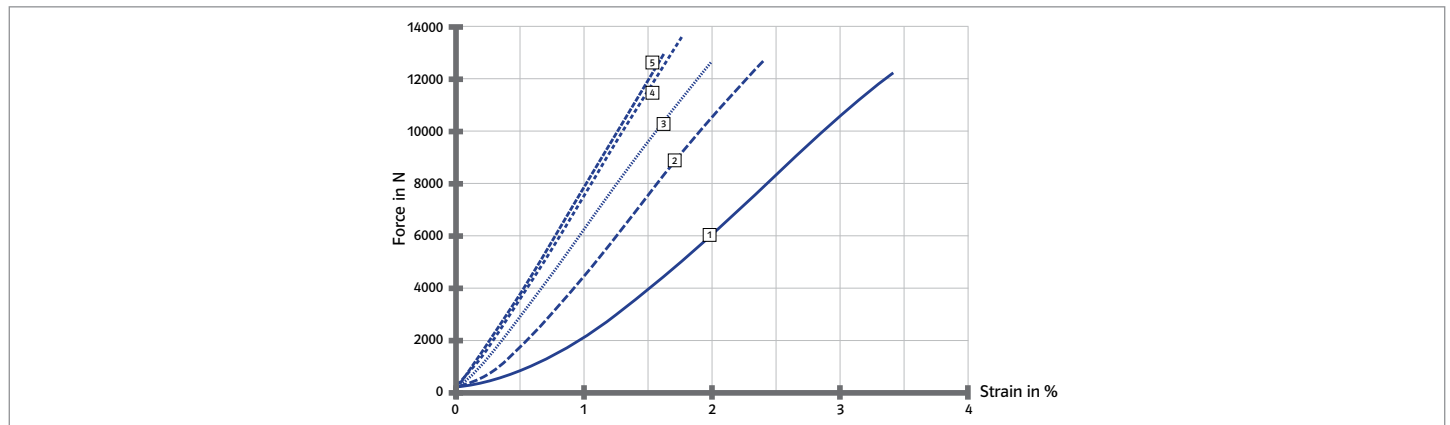

### 3.2.12 | Smart Band® 19mm Hybrid – POM (Acetal)

Line No	Band Size	Material	Test Diameter	System Break Strength			Circumferential Break Strain
			mm	N	kgf	lbf	%
1	19mm (¾")	POM (Acetal)	200	9490	968	2133	4.0
2			280	9110	929	2048	2.6
3			400	9030	921	2030	2.4
4			600	9980	1018	2244	2.3
5			800	11010	1123	2475	2.1

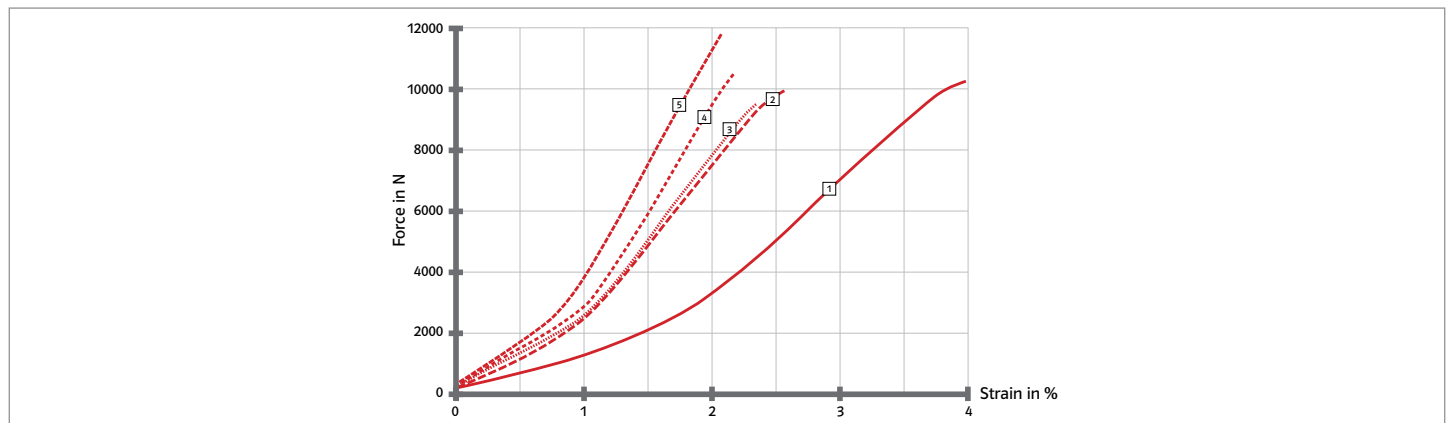

### Conclusion

- The Elastic Modulus (gradient of the curve) increases with the diameter. This is because the Smart Band® buckle bends and stretches further, the smaller the diameter.

## 3.2 | System Tensile

### 3.2.13 | Smart Band® 32mm Hybrid - PA11GF (Nylon 11 Glass-filled)

Line No	Band Size	Material	Test Diameter	System Break Strength			Circumferential Break Strain
			mm	N	kgf	lbf	%
1	32mm (1¼")	PA11GF (Nylon 11 Glass-filled)	200	19290	1968	4336	7.0
2			280	21680	2211	4874	4.2
3			400	21510	2194	4835	2.9
4			600	25010	2551	5622	2.3
5			800	24910	2541	5600	2.3

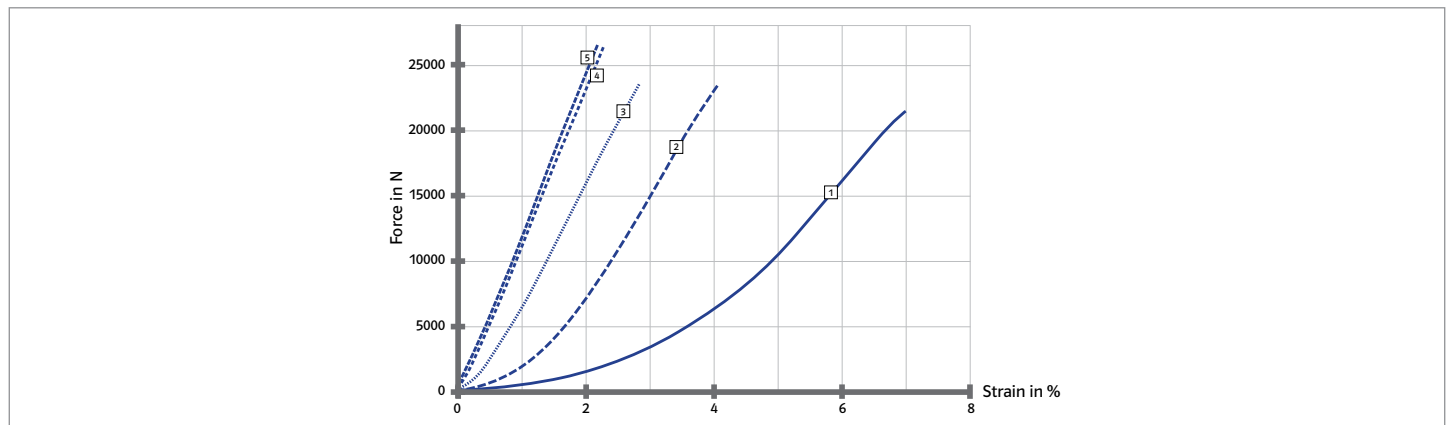

### 3.2.14 | Smart Band® 32mm Hybrid - POM (Acetal)

Line No	Band Size	Material	Test Diameter	System Break Strength			Circumferential Break Strain
			mm	N	kgf	lbf	%
1	32mm (1¼")	POM (Acetal)	200	15180	1548	3412	6.5
2			280	16500	1683	3709	4.2
3			400	16090	1641	3617	3.1
4			600	17200	1754	3867	2.5
5			800	17380	1773	3907	2.4

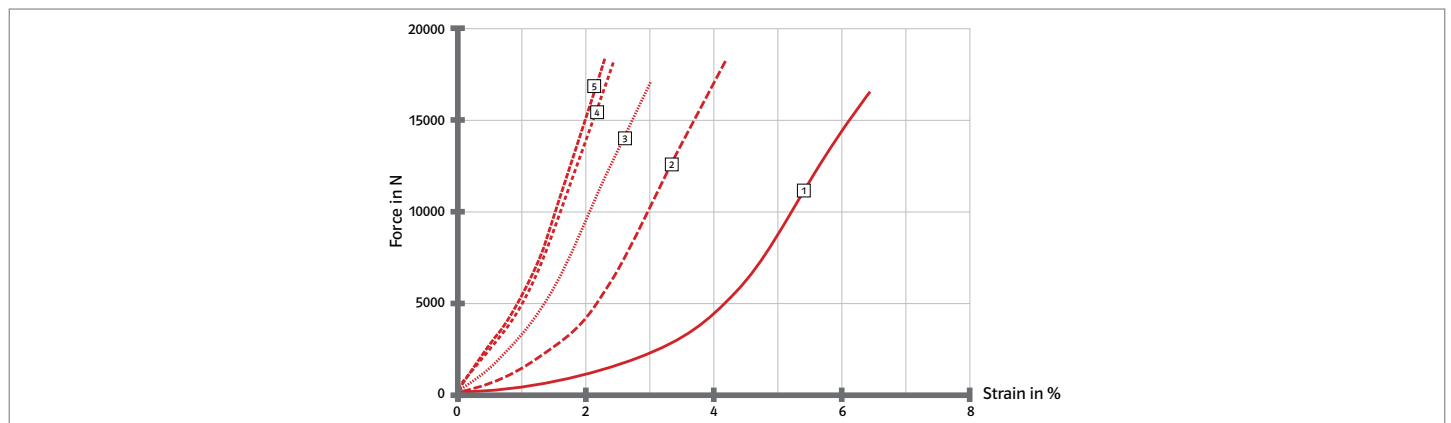

### Conclusion

- The Elastic Modulus (gradient of the curve) increases with the diameter. This is because the Smart Band® buckle bends and stretches further, the smaller the diameter.

## 3.3 | Effect of Moisture on Tensile Strength

Smart Band® 32mm samples were immersed in fresh water for 8 months and then tested to determine the effects of moisture absorption on Tensile strength.

### 3.3.1 | Post 8-month Fresh Water Immersion Smart Band® Straight Band Tests

Line No	Band Size	Band Material	Test Description	Break Strength		
				N	kgf	lbf
1	32mm (1¼")	PA11GF (Nylon 11 Glass-filled)	Straight Band	21,870	2,229	4,905
2		POM (Acetal)	Straight Band	16,700	1,702	3,745

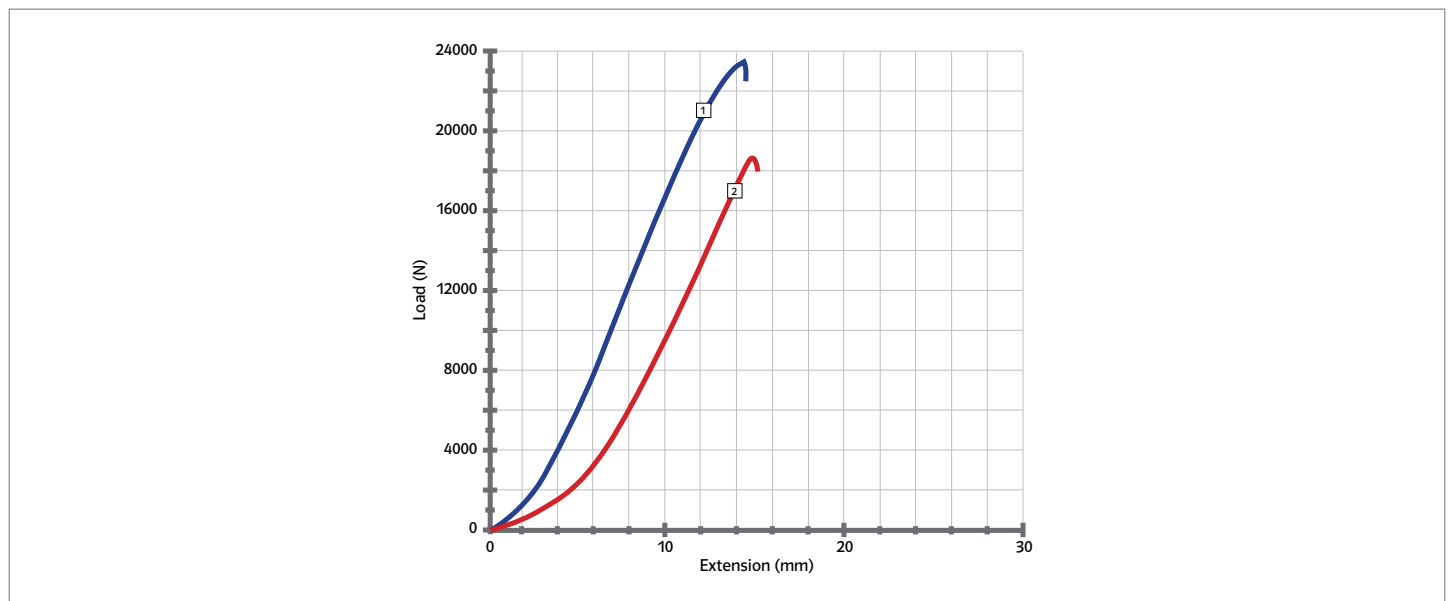

### 3.3.2 | Post 8-month Fresh Water Immersion Smart Band® Hybrid System Strength Tests

Line No	Band Size	Band Material	Test Description	Break Strength		
				N	kgf	lbf
3	32mm (1¼")	PA11GF (Nylon 11 Glass-filled)	System 300mm (11.8inch) Radius	21,270	2,168	4,770
4		POM (Acetal)	System 300mm (11.8inch) Radius	16,540	1,686	3,709

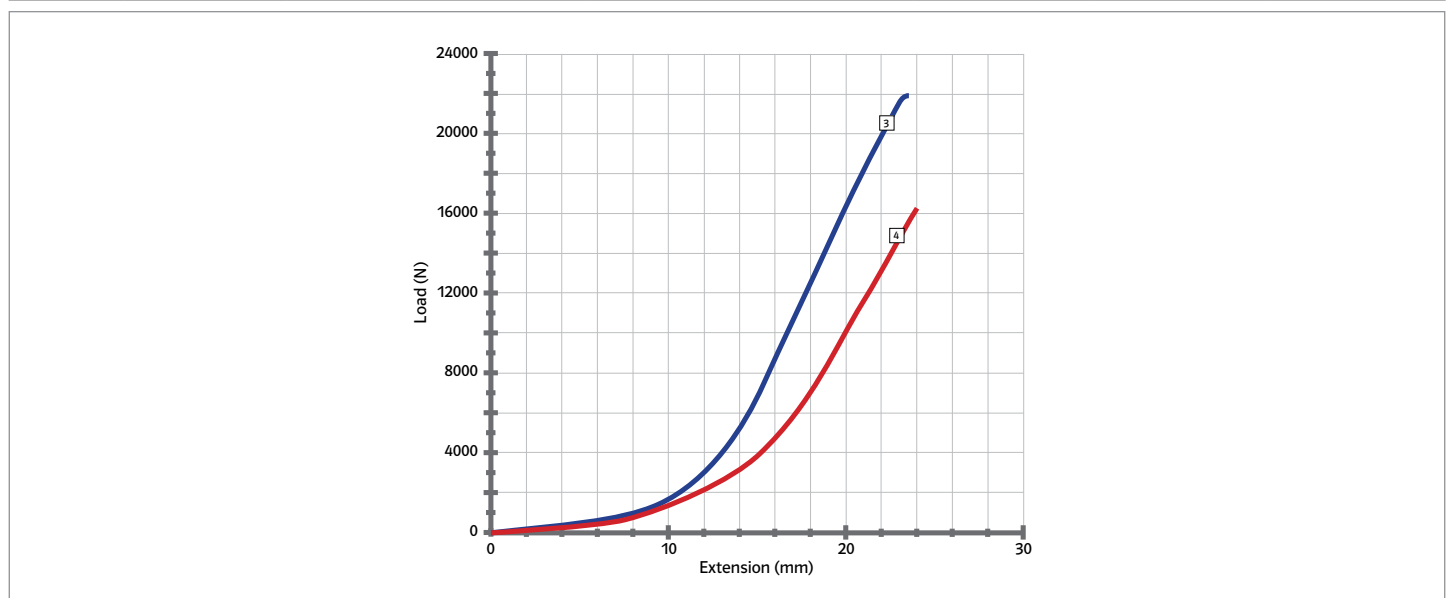

## 3.4 | System Creep

The phenomena known as creep is exhibited in many materials particularly when they are put into tension or compression. Smart Band® is made from a combination of engineering polymers, which possess strong creep resistant characteristics, in combination with glass fibre yarn to reduce the effects of creep to a minimum.

The chemical composition of **PA11GF (Nylon 11 Glass-filled)** gives good creep resistant properties, as summed up by Arkema in their technical book "RILSAN® Polyamide 11 in oil and gas, page 6"

*"The excellent properties of polyamides and in particular polyamide 11 are a result of the amide linkages in the chain which allow a strong interaction between the chains by hydrogen bonds. Low creep, high abrasion resistance, good resistance to fatigue and high barrier properties are a direct result of these strong inter-chain interactions."*

The graphs below, show the estimated creep over time for Smart Band® Hybrid systems:

Line No	Band Size	Band & Buckle Material	Starting System Force	Tension after 1 Year Approx	Tension after 5 Years Approx	Tension after 25 Years Approx
			N	N	N	N
1	19mm (¾")	PA66 (Nylon 6.6.)*	5,000	4,000	3,900	3,800
2		PA11GF (Nylon 11 Glass-filled)	5,000	3,300	3,100	2,900
3		POM (Acetal)	5,000	3,100	2,800	2,600
4	32mm (1¼")	PA11GF (Nylon 11 Glass-filled)	10,000	6,600	5,900	5,400
5		POM (Acetal)	10,000	6,000	5,500	4,800

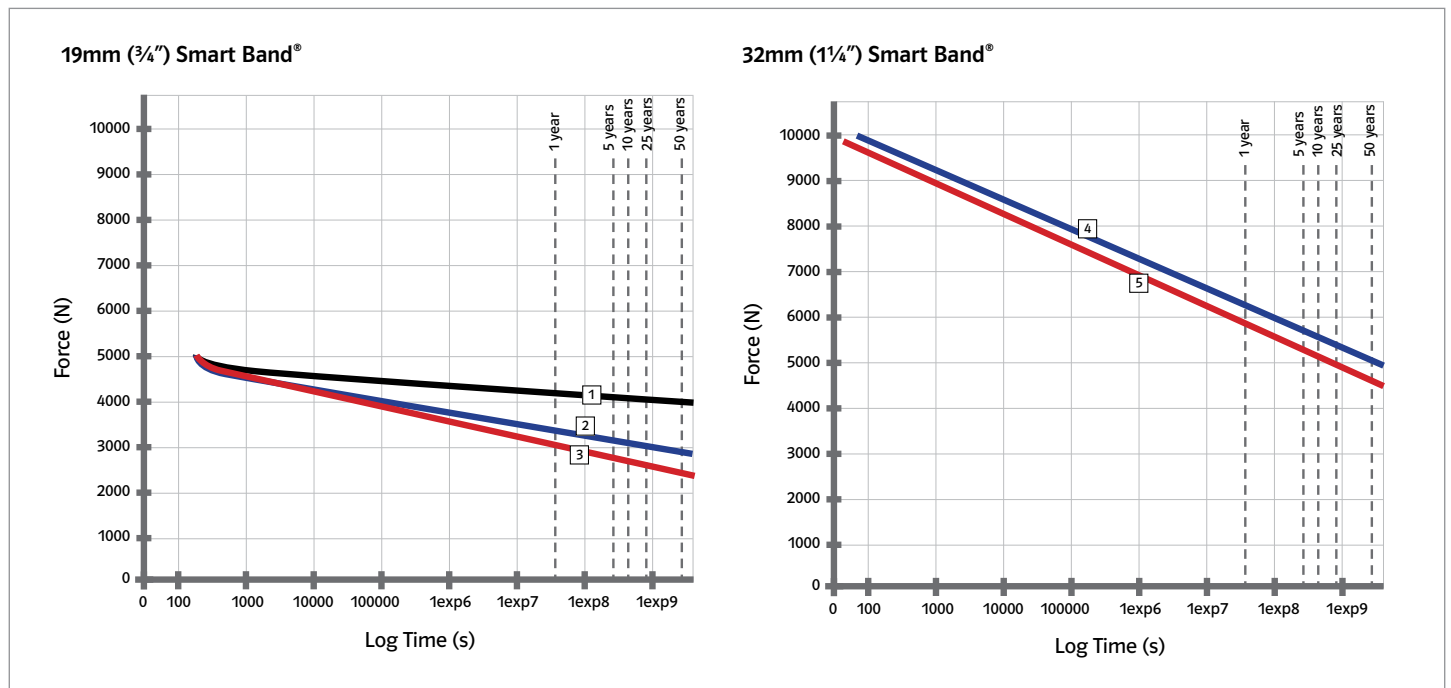

\*Due to the hygroscopic nature of **PA66 (Nylon 6.6.)**, the retention force would be less than shown if immersed in water.

## 3.5 | Impact Resistance

Impact Resistance can be important in any application, but is often of particular importance in offshore applications. The impact resistance of an object can be tested by dropping a known weight from a known height. The standard energy equation – Energy (Joules) = MGH is applied where:

- M = Mass Kg
- G = Gravity 9.81 m/s<sup>2</sup>
- H = Height m

The weight is adjusted accordingly to set the correct impact energy but the bottom impact area of the weight is always 100mm (4 inches) in diameter.



### 3.5.1 | Impact test results for Smart Band®:

Size/Component	Material	Maximum Impact Energy Without Loss of Integrity or Tension
		J
19mm (¾") Band	PA11GF (Nylon 11 Glass-filled)	5000+*
19mm (¾") Buckle	PA11GF (Nylon 11 Glass-filled)	5000+*
32mm (1¼") Band	PA11GF (Nylon 11 Glass-filled)	5000+*
32mm (1¼") Buckle	PA11GF (Nylon 11 Glass-filled)	5000+*

\*The material maintained integrity after impacts of maximum possible energy from apparatus used 176Kg x 9.81 m/s<sup>2</sup> x 2.91m = 5000 Joules (2 sig fig).

## 3.6 | Piggyback Pipe Lay

The following tests were carried out to obtain a comparison in the performance between the Smart Band® 32mm (1¼") PA11GF (Nylon 11 Glass-filled) Hybrid system and 32mm (1¼") Nickel Alloy 625 when used in a Piggyback Pipe Lay application. During the tests a Piggyback saddle arrangement was loaded with radial, axial and lateral forces. For axial and lateral loading, the movement of the saddle was measured relative to the carrier pipe; for radial loading, the system break strength was recorded.

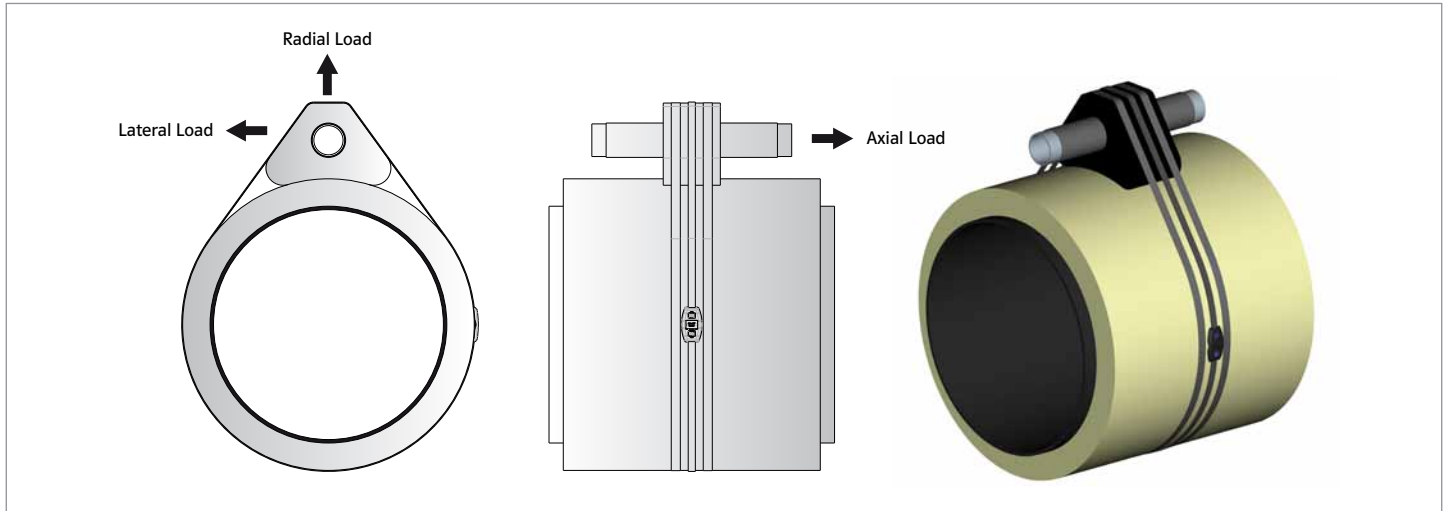

### 3.6.1 | Tool Tightening Forces:

Pneumatic Tightening Tool Type	Air Pressure			System Retention		
	MPa	Bar	psi	N	Kg	lbs
32mm (1¼") Smart Band – Air ratchet W2301	0.4	4.0	58	8000	815	1794
32mm (1¼") Steel strap – Signode PRHR-114	0.6	6.0	87	6200	632	1390

### 3.6.2 | Test Results:

Loading Direction	Saddle Type	Pipe Diameters		Surface Movement <sup>1</sup>	32mm (1¼") Smart Band PA11GF Strap			32mm (1¼") Nickel Alloy Strap	
					3 Straps	2 Straps	1 Strap	3 Straps	1 Strap
		mm	inch		mm	Installation <sup>2</sup> Loading kN	Operational <sup>3</sup> Loading kN	Operational <sup>4</sup> Loading kN	Installation <sup>2</sup> Loading kN
Axial	Polypropylene	600 + 120	24 + 5	50	9.2	7.3	2.9	5.9	2.9
	Rubber	600 + 120	24 + 5	50	15.4	13.5	8.4	17.0	8.2
Lateral	Polypropylene	600 + 120	24 + 5	50	4.1	3.4	1.8	4.1	1.6
	Rubber	600 + 120	24 + 5	50	6.3	7.6	4.3	4.9	2.1
Radial	Polypropylene	600 + 120	24 + 5	N/A	50+*	33.5	19.3	50+*	26.6 (22.1**)
	Rubber	600 + 120	24 + 5	N/A	50+*	31.1	15.6	50+*	24/4 (20.1**)

<sup>1</sup> Surface movement is the surface lateral movement of the saddle against the pipe

<sup>2</sup> Installation Arrangement includes 2 x carbon steel straps and 1 x Smart Band Strap or 1 x super nickel alloy strap

<sup>3</sup> Operational Arrangement includes 2 x Smart Band Strap or 2 x super nickel alloy strap

<sup>4</sup> Operational Arrangement includes 1 x Smart Band Strap or 1 x super nickel alloy strap

\*System yield, where lower than break strength

\*\*System survived maximum tensile force of 50kN

## Conclusion

- Smart Band® 32mm (1¼") PA11GF (Nylon 11 Glass-filled) performed slightly better than the 32mm (1¼") Nickel Alloy 625 under Lateral and Axial loading, due to the higher tightening force produced by the fitting tool.
- Nickel Alloy 625 performed slightly better under Radial loading, due to its system break strength being higher than that of Smart Band®.
- The Rubber piggyback saddle performed better than the polypropylene piggyback saddle for Axial and Lateral loading, due to having a higher coefficient of friction against the steel pipe.

It should be noted that these tests were carried out on two particular arrangements as defined in the table above and that clients should carry out their own tests, as Piggyback arrangements vary from application to application.

**3.7 | Half Shell Minimum Bending Radius**

Due to a dynamic environment, umbilicals and risers are often subjected to aggressive bending.

The test MBR (Minimum Bend Radius) is usually a few metres but to ensure absolute compliance and to give a good safety factor, they are often subjected to a much tighter radii.

Smart Band® has been well proven to stand an MBR of less than one metre for this type of application.



Photo courtesy of Lankhorst/Mouldings BV

19mm/3/4" Smart Band® PA11GF clamped on a UraGUARD Half Shell Test

**Minimum Bend Radii:** 0.68m

**Water depths:** 600m to 1200m

**Final Installation Location:** West Coast of Angola

## 3.8 | Hydrostatic Compression

In deep water applications hydrostatic compression is a factor that needs to be taken into account when objects are clamped. In applications such as strake, cable/riser protection and buoyancy the high pressures in deep water have a crushing effect on the material causing the overall diameter to reduce. The strapping solution needs to be able to take up the reduction in diameter to give continual retention to the object being clamped.

Smart Band® is better suited to cope with Hydrostatic Compression when compared with traditional steel strapping solutions because of its lower strap stiffness. Elongation is higher under tension than steel and so as compression takes place, band tension reduces less than steel which will lose tension quickly as compression takes place.



### 3.8.1 | Example of a Typical Hydrostatic Compression Test Simulation

The following graphs give an example using 32mm Smart Band PA11GF around a 353mm diameter half shell arrangement. The two steel half shells have a polyethylene surface to simulate a polyethylene strake. The Smart Band® is tightened using a calibrated SM-FT-1000 torque shut-off tool. Over a period of 24 hours the diameter is reduced by 2.7mm to simulate the strake being lowered and experiencing hydrostatic compression. The system is then left for 10 days to determine any creep that might take place. On graph 3.8.1 log time has been extrapolated to give the estimated retention over many years.

**Note:** The polyethylene surface is smoother than the steel surface and so friction does not have as much effect. The initial tension is therefore higher at around 10%.

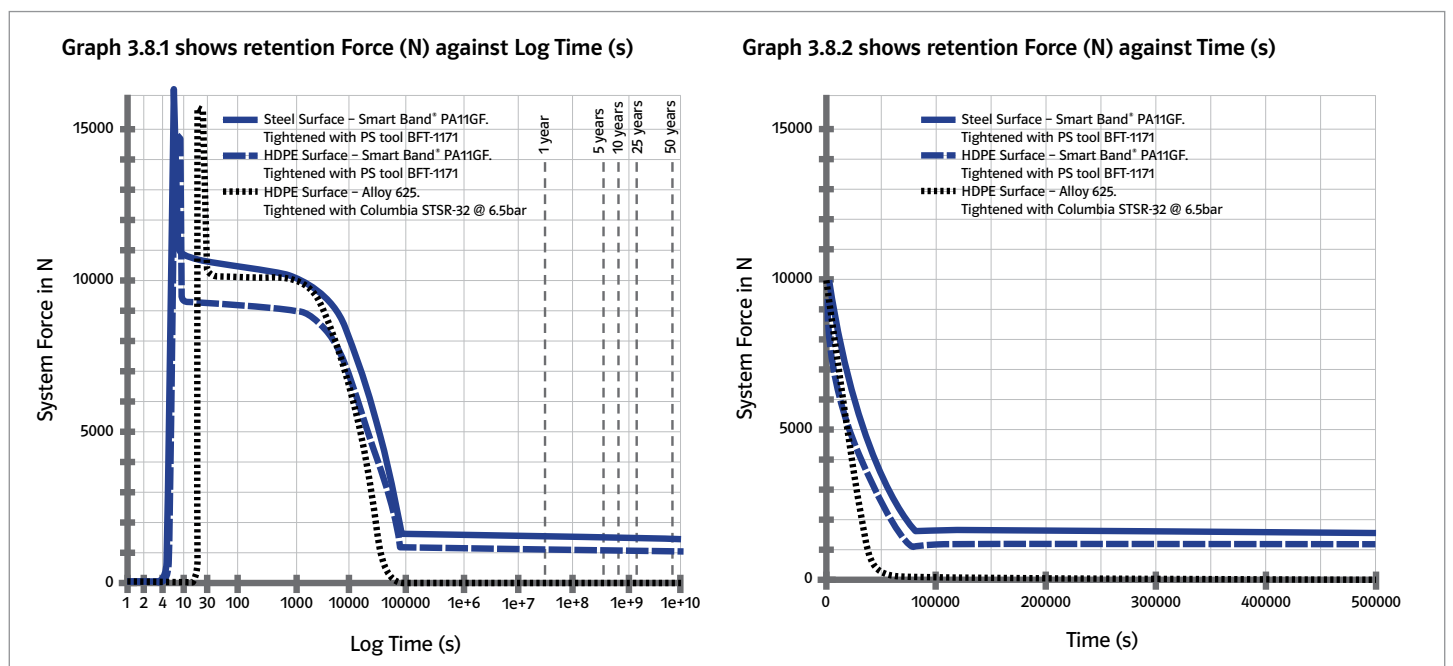

Note: Customer tests can be performed for individual applications

### 4.1 | Abrasion

Smart Band® has been widely used in offshore applications where abrasion is a factor.

The banding has been proven to withstand abrasive conditions and shock from foreign debris that are often evident near the shore line.

	Description	Standard	PA66 (Nylon 6.6.)	PA11 (Nylon 11)	PA11GF (Nylon 11 20% Glass-filled)	POM (Acetal)
			Dry As Moulded	Dry As Moulded	Dry As Moulded	
<b>Mechanical Properties</b>						
<b>Abrasion Resistance</b>	The susceptibility to wear caused by abrasion. The figures shown are relative to Nylon 11, which is the best; i.e. x2.8 means 2.8 times the wear of Nylon 11.	NFT 46-102	2.8	1	2	10

### 4.2 | Marine Growth

Smart Band® has been well proven in applications such as pile wrapping where marine growth is a common factor. The integrity of the buckle and band is not compromised by marine growth and the banding remains permanently tight in this aggressive environment.

The photo on the left shows Smart Band® 10mm (3/8") in Nylon 6.6. fitted to a pier pile jacket on the southern coast of the United Kingdom. The second photo on the right shows the same pile after 5 years. Smart Band® is still performing well and is unaffected by the barnacle growth.



Photos courtesy of Winn & Coales (Denso) Ltd  
Location: UK South Coast

## 4.3 | Temperature Resistance

The following information gives maximum and minimum temperature recommendations for Smart Band® and Smart Tie™.

- It should be noted that the higher the temperature the lower the retention and tension that the banding exerts when tightened.
- It is important that full tests are carried out to ensure suitability for applications especially where raised temperatures are an issue.
- There may also be other chemicals\* in the vicinity that can adversely affect the performance of the polymers especially at higher temperatures and should be considered when specifying Smart Band® and Smart Tie™ in aggressive high temperature environments.

\*Refer to the 'Chemical Resistance' section for more information.

	Description	Standard	Units
<b>Temperature Recommendations</b>			
<b>Working Temperature</b>	General guidelines on permissible application temperatures		
<b>Minimum</b>			°C (°F)
<b>Maximum Continuous</b>			°C (°F)
<b>Occasional Peaks</b>			°C (°F)
<b>Thermal Properties</b>			
<b>Melting Point</b>	The temperature at which the Polymer melts, i.e. turns from a solid to a liquid	ISO 11357	°C (°F)
<b>Heat Deflection Temperature</b>	A measure of short-term heat resistance. A test specimen is loaded in a 3-point bending configuration, then heated until a specified deflection is reached		
<b>1.82 MPa</b>		ISO 75	°C (°F)
<b>0.45 MPa</b>		ISO 75	°C (°F)
<b>Vicat Softening Temperature</b>	The temperature at which a flat-ended needle penetrates a test specimen to a depth of 1mm under a specified load		
<b>50N</b>		ISO 306	°C (°F)
<b>10N</b>		ISO 306	°C (°F)
<b>Coefficient of Linear Thermal Expansion</b>	A measure of the change in size of an object as its temperature changes		
<b>2mm - Parallel, 23°C - 55°C</b>		ISO 11359	10 <sup>-5</sup> mm/mm/°C
<b>2mm - Normal, 23°C - 55°C</b>		ISO 11359	10 <sup>-5</sup> mm/mm/°C
<b>Working Temperature</b>	General guidelines on permissible application temperatures		
<b>Minimum</b>			°C (°F)
<b>Maximum Continuous</b>			°C (°F)
<b>Occasional Peaks</b>			°C (°F)
<b>Flammability</b>			
<b>Flame Resistance (0.75 - 3.0mm Thickness):</b>	V-2 rating: Burning stops within 60 seconds after two applications of ten seconds each of a flame to a test bar. Flaming drips ARE allowed. H-B rating: Slow horizontal burning on a specimen where the burning rate is less than 3"/min or stops burning before the 5" mark. H-B rated materials are considered "self-extinguishing". This is the lowest (least flame retardant) UL94 rating.	UL 94	Class

# MATERIAL

## 4.3 | Temperature Resistance



Photo courtesy of William Crawford and IODP-USIO  
Smart Ties holding the maze of tubing lines feeding into downhole packers

PA66 (Nylon 6.6.)		PA11 (Nylon 11)		PA11GF (Nylon 11 20% Glass-filled)		POM (Acetal)
Dry As Moulded	Conditioned (50% RH)	Dry As Moulded	Conditioned (50% RH)	Dry As Moulded	Conditioned (50% RH)	
-30 (-22)		-40 (-40)		-40 (-40)		-30 (-22)
125 (257)		105 (221)		115 (239)		95 (203)
170 (338)		130 (266)		140 (284)		130 (266)
260 (500)		189 (372)		189 (372)		
70 (158)		50 (122)		175 (347)		95 (203)
200 (392)		145 (293)		180 (356)		156 (313)
236 (457)		160 (320)		170 (338)		
255 (491)		180 (356)				160 (320)
1.1		8.5		5		10
1.2						
-30 (-22)		-40 (-40)		-40 (-40)		-30 (-22)
125 (257)		125 (257)		135 (275)		95 (203)
170 (338)		150 (302)		160 (320)		130 (266)
V-2	V-2	V-2	V-2	HB	HB	HB

## 4.4 | Material Properties

### 4.4.1 | Polymer

	Description	Standard	Units
<b>Physical Properties</b>			
<b>Density</b>	Mass per Volume, also known as 'Specific Gravity'. The units $\text{g/cm}^3 = \text{g/ml}$	ISO 1183	$\text{g/cm}^3$ (oz/inch <sup>3</sup> )
<b>Water Absorption at 23°C:</b>	The mass of water absorbed from the atmosphere as a % of the total mass:		
<b>24 hours at 50% RH</b>	- 24 hours after moulding.	ISO 62	%
<b>Equilibrium at 50% RH</b>	- When an equilibrium (constant quantity) is reached.	ISO 62	%
<b>Saturation (in water)</b>	- The maximum mass of water that can potentially be absorbed.	ISO 62	%
<b>Mechanical Properties</b>			
<b>Tensile:</b>	Material properties exhibited whilst under tension. A test specimen is held at both ends and loaded so that the specimen is stretched under tension.		
<b>Modulus</b>	A measure of the stiffness of a material during elastic (non-permanent) deformation. Tensile Modulus = Tensile Stress / Tensile Strain = (Force / Area) / (Increase in Length / Original Length)	ISO 527	MPa
<b>Strength at Yield</b>	The Stress (Force per Area) required to yield a test bar, i.e. to cause plastic (permanent) deformation	ISO 527	MPa
<b>Strength at Break</b>	The Stress (Force per Area) required to break a test bar	ISO 527	MPa
<b>Elongation at Yield</b>	The % increase in length of a test bar at the Yield point, i.e. at the onset of plastic (permanent) deformation. Elongation = Strain x 100	ISO 527	%
<b>Elongation at Break</b>	The % increase in length of a test bar at the break point, i.e. when the material fractures. Elongation = Strain x 100	ISO 527	%
<b>Flexural:</b>	Material properties exhibited whilst under flexure (bending). A test specimen is supported at both ends and a load applied at the mid-point of the specimen in order to cause 3-point bending.		
<b>Modulus</b>	A measure of the stiffness of a material during elastic (non-permanent) deformation. Flexural Modulus = Flexural Stress / Flexural Strain = $\{(3 \times \text{Force} \times \text{Length}) / (2 \times \text{Width} \times \text{Height}^2)\} / \{(6 \times \text{Deflection} \times \text{Height}) / (\text{Length}^3)\}$ = $(\text{Force} \times \text{Length}^3) / (4 \times \text{Width} \times \text{Height}^3 \times \text{Deflection})$	ISO 178	MPa
<b>Strength</b>	Also known as 'Modulus of Rupture' or 'Bend Strength'. The Stress required to break a test bar through 3-point bending.	ISO 178	MPa
<b>Impact Resistance:</b>	The relative susceptibility to fracture under stresses applied at high speeds.		
<b>Charpy at +23°C (73°F)</b>	The energy required to fracture a sample held in a 3-point bending configuration.	ISO 179	kJ/m <sup>2</sup>
<b>Charpy at -30°C (-22°F)</b>		ISO 179	kJ/m <sup>2</sup>
<b>Charpy notched at +23°C (73°F)</b>		ISO 179	kJ/m <sup>2</sup>
<b>Charpy notched at -30°C (-22°F)</b>		ISO 179	kJ/m <sup>2</sup>
<b>Electrical Properties</b>			
<b>Dielectric Strength (step-by-step) 3.0mm</b>	The voltage required to produce dielectric breakdown of the material, i.e. the maximum voltage the material can insulate per unit thickness.	DIN IEC 60243	kV/mm
<b>Volume Resistivity 3.0mm</b>	The resistance to the flow of electric current through the body of a material.	DIN IEC 60093	$\times 10^{11}$ ohm-m
<b>Surface Resistivity 3.0mm</b>	The resistance to the flow of electric current along the surface of a material.	DIN IEC 60093	$\times 10^{12}$ ohm
<b>Comparative Tracking Index 3.0mm</b>	The voltage which causes tracking after 50 drops of 0.1% ammonium chloride solution have fallen on the material. The results of testing at 3 mm thickness are considered representative of the material's performance in any thickness. Tracking is an electrical breakdown on the surface of an insulating material. A large voltage difference gradually creates a conductive leakage path across the surface of the material by forming a carbonized track.	DIN IEC 60112	V

## 4.4 | Material Properties

PA66 (Nylon 6.6.)		PA11 (Nylon 11)		PA11GF (Nylon 11 20% Glass-filled)		POM (Acetal)
Dry As Moulded	Conditioned (50% RH)	Dry As Moulded	Conditioned (50% RH)	Dry As Moulded	Conditioned (50% RH)	
1.14 (0.66)		1.03 (0.60)		1.18 (0.68)		1.41 (0.82)
1.1						
2.4		0.9		0.6		-0.25
8.5		1.9		1.5		-0.35
3000	1400	1450	1230	4380	3980	2550
83	66	42	40			
		69		93	90	63
4.5	25	6	8			
25	105	380		9	10	60
2900	1350		1100			2600
86	22					88
No break			No break		76	
No break			No break		74	
6.6			23		21	9
5.3			13		12	
20			30		45	
400			10		7	
			100		100	
400-599					600	

## 4.4 | Material Properties

### 4.4.2 | Glass Fibre Yarn - Ø1mm

	Description	Units	Description
<b>Physical Properties</b>			
Density	Mass per Volume, also known as 'Specific Gravity'. The units $g/cm^3 = g/ml$	$g/cm^3$ (oz/inch <sup>3</sup> )	2.60 (1.50)
Moisture Content (ISO 3344)	Moisture content lost after drying at 105°C	%	0.70
<b>Mechanical Properties</b>			
Tensile:	Material properties exhibited whilst under tension. A test specimen is held at both ends and loaded so that the specimen is stretched under tension.		
Strength at Break	The Tensile Strength of an individual yarn at the Break point, i.e. when the material fractures	N	960
Elongation at Break	The % increase in length of an individual yarn at the break point, i.e. when the material fractures. Elongation = Strain x 100	%	2
<b>Thermal Properties</b>			
Melting Point	The temperature at which the Glass melts, i.e. turns from a solid to a liquid	°C (°F)	750 (1382)
<b>Flammability</b>			
Loss on Ignition	The mass of material lost following ignition (volatile substances are burned off)	%	1



### Virgin E-Glass

<b>Physical Properties</b>			
Density	Mass per Volume, also known as 'Specific Gravity'. The units $g/cm^3 = g/ml$	$g/cm^3$ (oz/inch <sup>3</sup> )	2.08 (1.20)
Hardness (Vickers 50g-15s)	A measure of the hardness of the material as determined by the Vicker's test method; in this case a 50g weight was used for a duration of 15s		5.6
<b>Thermal Properties</b>			
Littleton Softening Temperature	The temperature at which glass deforms visibly under its own weight; defined as the log <sub>10</sub> (viscosity) is 6.6 Pa s.	°C (°F)	840 (1544)
Coefficient of Linear Thermal Expansion	A measure of the change in size of an object as its temperature changes	$10^{-5} \text{ mm/mm/}^\circ\text{C}$	53
Specific Heat	The heat capacity per unit mass of a material		
20°C		J/g°K	0.764
200°C	J/g°K		0.958
Coefficient of Thermal Conductivity	A measure of a material's ability to conduct heat	W/m°K	1.0
<b>Electrical Properties</b>			
Dielectric Constant	The voltage required to produce dielectric breakdown of the material, i.e. the maximum voltage the material can insulate per unit thickness.		
1 MHz			6.4
1 GHz			6.13
Volume Resistivity	The resistance to the flow of electric current through the body of a material.	Ohm-cm	1014 - 1015
Surface Resistivity	The resistance to the flow of electric current along the surface of a material.	Ohm	1013 - 1014

## 4.5 | Offshore/Subsea Environments

One of the main benefits of using **PA11 (Nylon 11)** and **PA11GF (Nylon 11 Glass-filled)** in offshore applications is the very low degradation due to water and a whole variety of petrochemicals. Track records since **PA11 (Nylon 11)** and **PA11GF (Nylon 11 Glass-filled)** were first introduced over 50 years ago, show extremely high resistance to a whole variety of offshore chemical environments.

### 4.5.1 | Lifetime of PA11 in different chemical environments

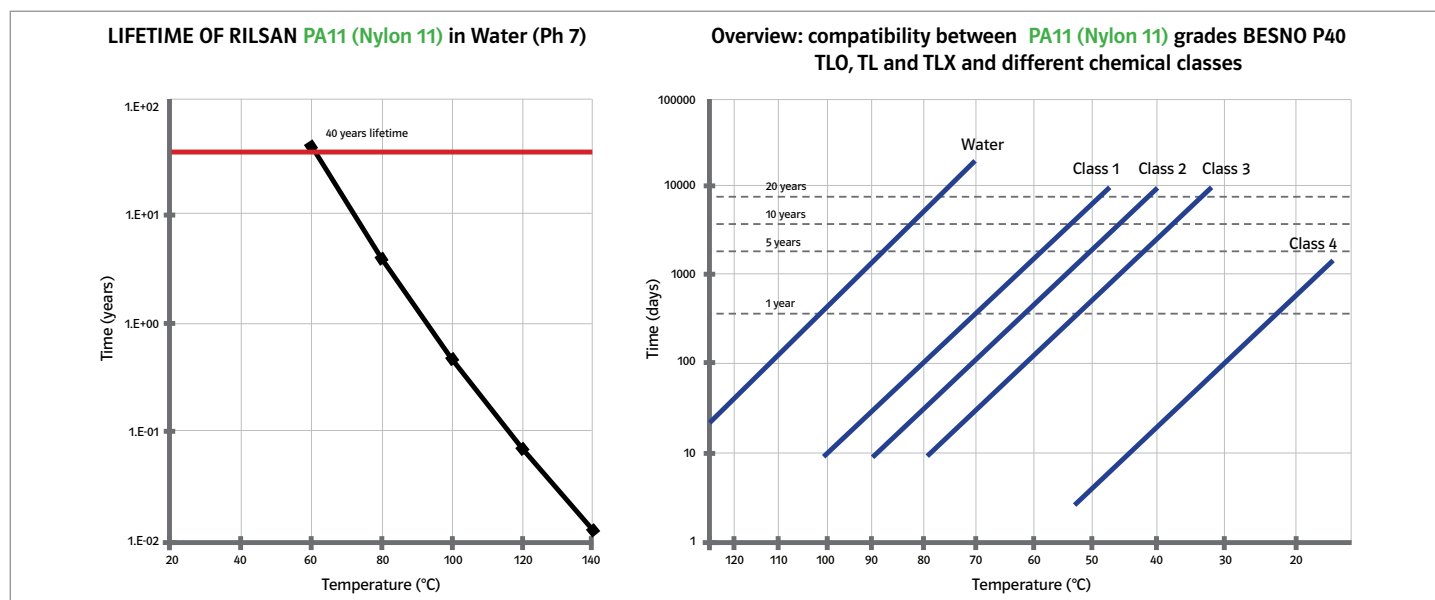

Water is the critical chemical medium for Polyamides (such as PA11). Deionised water (pH = 7) does not contain salts (such as Sodium Chloride), so the probability of chemical interaction between the water molecules and the amide groups is maximised. Salt water contains salts which do not interact with the Polyamide. The salts bind a certain amount of water by forming a shell of water molecules around each salt ion. The presence of salts therefore reduces the speed of the water absorption of the Polyamide.

### 4.5.2 | Overview of Chemical Classes

Chemical	Liquid Base	Functions	Compatibility Class
oxypropylated and/or oxyethylated alkylphenols "non ionic surfactants"	hydrocarbon, water/glycol	demulsifier	< water
ethylene oxide/propylene oxide copolymers	hydrocarbon	demulsifier	< water
glycol esters	hydrocarbon	demulsifier	< water
fatty amines	hydrocarbon, water, water/glycol	corrosion inhibitor	class 1
imidazoline derivatives	hydrocarbon, water, water/glycol	corrosion inhibitor	class 1
sulphite derivatives	water, water/glycol	corrosion inhibitor	class 2
bisulphite salts	water	oxygen scavenger	class 2
quaternary ammonium salts, "quats", ammonium salts	water, water/glycol	biocides	< water
aldehydes	water, water/glycol	biocides	class 2
polyacrylates	water, water/glycol	paraffine inhibitors scale inhibitors	class 1
organic phosphonates	water, water/glycol	scale inhibitors corrosion inhibitors	class 3
organic sulfonates	water, water/glycol	scale inhibitors corrosion inhibitors	class 3
hydrochloric acid 15%	water	well stimulation	class 4
hydrofluoric acid 15%	water	well stimulation	class 4

The sign "< water" means that the chemical is less aggressive than water.

**NB.** For the effects of moisture absorption on Smart Band® Tensile Strength, please see section 3.3

## 4.6 | Weathering

When exposed to weathering, polymers have a natural tendency to photo-oxidise and depolymerise to their natural elemental forms. There are variations in natural weathering depending on the intensities of the following components:

- Solar Radiation (UV)
- Moisture
- Heat
- Pollutants e.g. ozone and acid rain
- Salt Water

The combination of more than one of these factors can also lead to accelerated degradation and aging.

Weathering intensity varies widely around the world, and may also vary from year to year for a given location, depending on weather patterns. Weather in a subtropical climate, such as Florida, may have twice the effect on a polymer as a more northerly location. A drier climate, such as Arizona, may have increased UV radiation, but because of the lower humidity, the effects of weathering on a polymer will not be so severe. It is impossible to give a precise indication of the effects of weathering in a given location, but by using natural outdoor and accelerated tests, certain predictions can be made.



Photo courtesy of Groupe Courbis  
Location: Malaysia

The carbon black additive in Smart Band® and Smart Tie™ products, acts as a very good UV stabiliser. Heat-stabilised grades, usually copper based, also provide further protection against photo-oxidative degradation by shutting down free radicals. This combination of inhibitors helps to give the polymers many years of life.

### 4.6.1 | Estimated Polymer life expectancy when exposed to weathering

Materials all black	Life in Hot climates	Life in Temperate Climates
	YRS – Approx	YRS – Approx
PA66 (Nylon 6.6.)	10+	15+
PA11 (Nylon 11)	15+	20+
PA11GF (Nylon 11 Glass-filled)	15+	20+
POM (Acetal)	5+	8+

## 4.6 | Weathering

### 4.6.2 | PA66 (Nylon 6.6.)

Compared with other polymers, **PA66 (Nylon 6.6.)** naturally exhibits a high resistance to weathering and UV degradation, even in its neat state. The graphs below, show the reduction in Tensile strength and Elongation at break of **PA66 (Nylon 6.6.)**, over a 2000 hour period in a weathering chamber. The accelerated weathering is achieved by wet and dry cycles and continuous UVA (320nm) exposure. The dry cycles last for 8 hours at 70°C, and the wet cycles for 4 hours.

#### PA66 (Nylon 6.6.) – reduction in Tensile strength, due to accelerated weathering

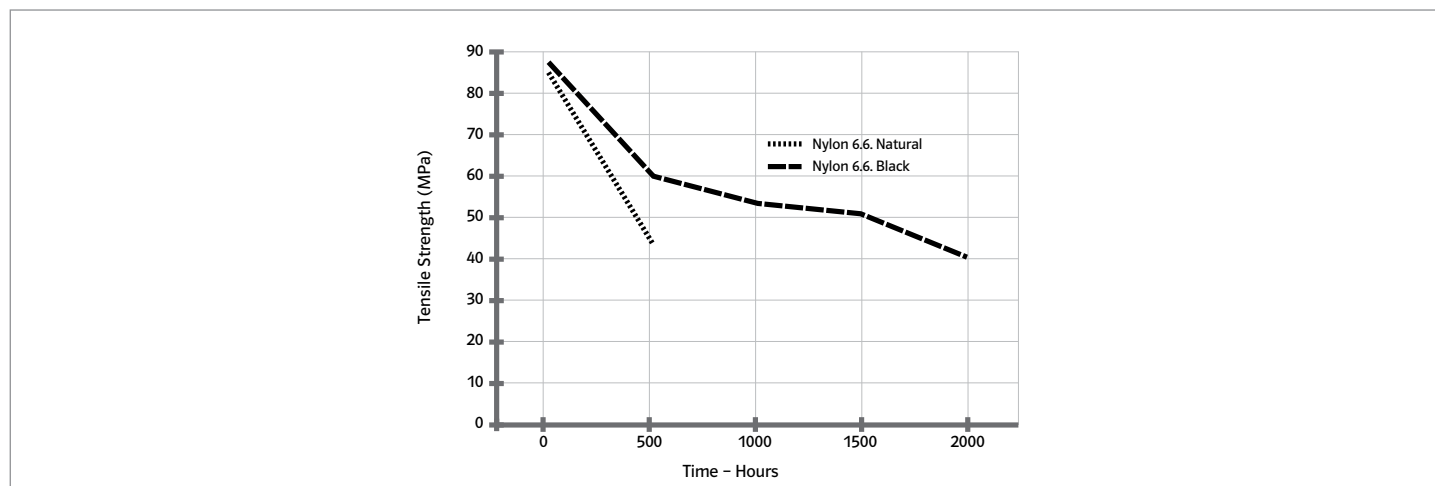

#### PA66 (Nylon 6.6.) – reduction in Elongation at break, due to accelerated weathering

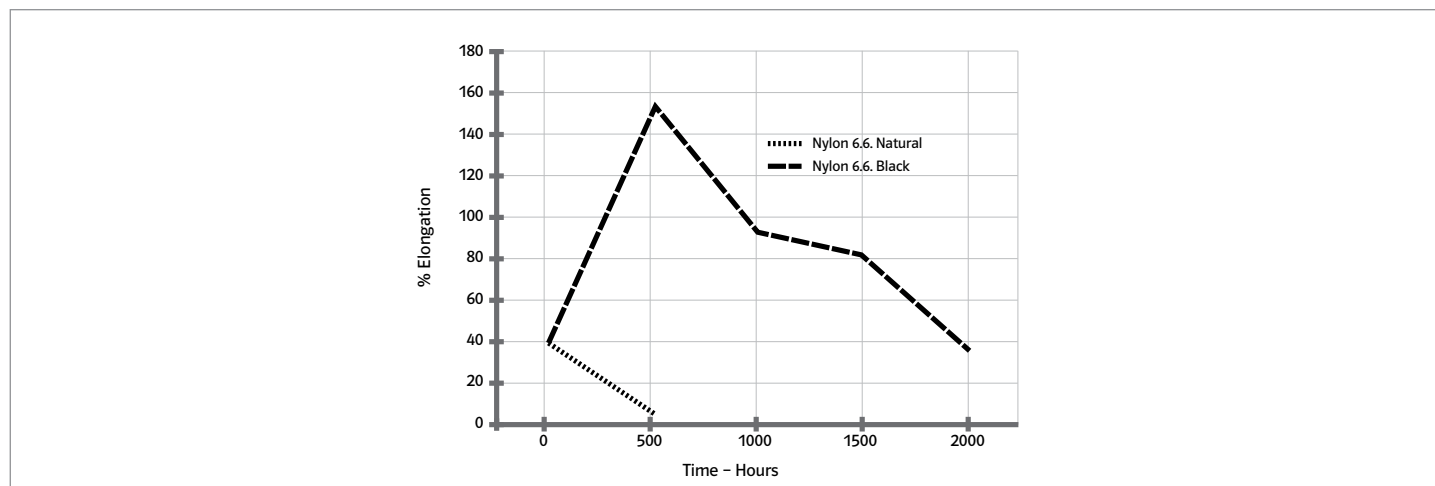

## Conclusion

- The degradation caused by weathering, in both the black and natural **PA66 (Nylon 6.6.)** tends to reduce the Tensile strength and the Elongation at break of the material over time. This makes the polymer weaker and more brittle.
- The carbon black UV stabiliser gives a huge increase in weathering resistance to **PA66 (Nylon 6.6.)**.
- It is important to note that the sharp fall in Tensile strength and increase in Elongation at break of Black **PA66 (Nylon 6.6.)** from 0 - 500 hours, is largely due to a conditioning effect (taking on moisture). However, the UV degradation that occurs in the natural material during this time is enough to annul the conditioning effect and to reduce the Elongation at break to almost zero.

## 4.6 | Weathering

### 4.6.3 | PA11 (Nylon 11)

The following data gives evidence that black PA11 (Nylon 11) is particularly resistant to degradation from the combined effect of the sun's rays and rain water. Black extruded tubes, 6 inch diameter x 8mm wall thickness, were tested at the following outdoor sites:

Serquigny, France	Moderate, moist climate. Typical of central Europe.
Bandol, France	Warm, moist climate. Typical of Mediterranean.
Iguazu, Brazil	Tropical climate with high sunlight irradiation.
Pretoria, South Africa	Hot, dry climate.

	Standard	Units	Control	1 Year	2 Year	3 Year	4 Year	5 Year	6 Year
<b>Serquigny, France</b>									
Inherent Viscosity (IV)		dl/g	1.42	1.54	1.55	1.64	1.66	1.62	1.63
Ultimate Tensile Strength (UTS)	ISO 527	MPa	37	38.5	37.2	42	37	36.5	35
Elongation at break (E)	ISO 527	%	357	329	338	347	291	309	316
Impact Test at -40°C (-40°F)	DIN 73378	Pass/Fail	Pass	Pass	Pass	Pass	Pass	Pass	Pass
Instantaneous Hoop Stress ( $\sigma$ )		MPa	24.3	24.9	25.1	26.0	30.7	29.5	27.0
<b>Bandol, France</b>									
Inherent Viscosity (IV)		dl/g	1.42	1.64	1.55	1.65	1.59	-	-
Ultimate Tensile Strength (UTS)	ISO 527	MPa	37	35	37	39	39	37.5	37
Elongation at break (E)	ISO 527	%	357	346	320	330	355	333	321
Impact Test at -40°C (-40°F)	DIN 73378	Pass/Fail	Pass	Pass	Pass	Pass	Pass	Pass	Pass
Instantaneous Hoop Stress ( $\sigma$ )		MPa	24.3	29.5	29.2	27.4	32	29	30
<b>Iguazu, Brazil</b>									
Inherent Viscosity (IV)		dl/g	1.42	1.63	1.65	1.66	1.72	1.62	1.57
Ultimate Tensile Strength (UTS)	ISO 527	MPa	37	42	38	38	39	37.4	39
Elongation at break (E)	ISO 527	%	357	358	295	317	347	374	370
Impact Test at -40°C (-40°F)	DIN 73378	Pass/Fail	Pass	Pass	Pass	Pass	Pass	Pass	Pass
Instantaneous Hoop Stress ( $\sigma$ )		MPa	24.3	28.4	25.6	26.0	31.5	33.0	29.7
<b>Pretoria, South Africa</b>									
Inherent Viscosity (IV)		dl/g	1.42	1.56	1.66	1.83	1.67	1.62	-
Ultimate Tensile Strength (UTS)	ISO 527	MPa	37	38.5	39	37	35	36	-
Elongation at break (E)	ISO 527	%	357	343	365	335	344	346	-
Impact Test at -40°C (-40°F)	DIN 73378	Pass/Fail	Pass	Pass	Pass	Pass	Pass	Pass	-
Instantaneous Hoop Stress ( $\sigma$ )		MPa	24.3	27.4	23.5	32.6	32.0	27.0	-

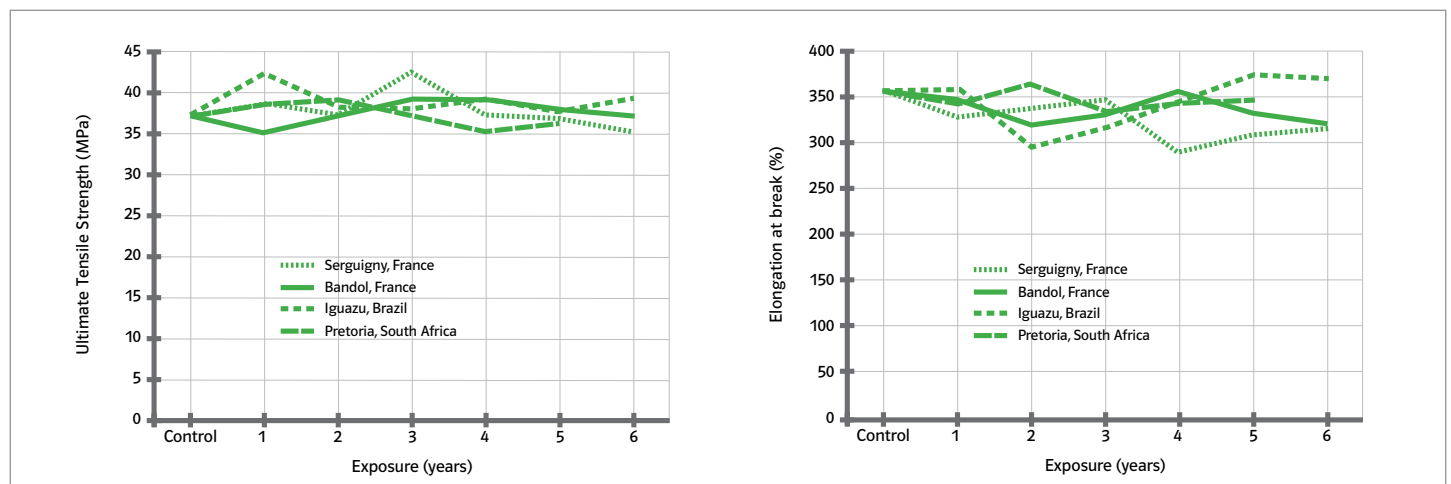

## Conclusion

- The degradation to black PA11 (Nylon 11) caused by weathering, can be seen to be minimal during the above tests. This gives great confidence that the life expectancy of PA11 (Nylon 11) is far longer than the exposure periods shown above.

## 4.6 | Weathering

### 4.6.4 | POM (Acetal)

When **POM (Acetal)** is exposed to UV radiation, a white deposit of degraded material forms on its surface, known as 'chalking'. There is a consequential loss of gloss and change in colour, as well as a deterioration in mechanical properties. The graphs below, show the effects of weathering on the Tensile Strength and Elongation at break of **POM (Acetal)**, through natural weathering and an accelerated test.

#### Outdoor Weathering Tests – Central European Climate

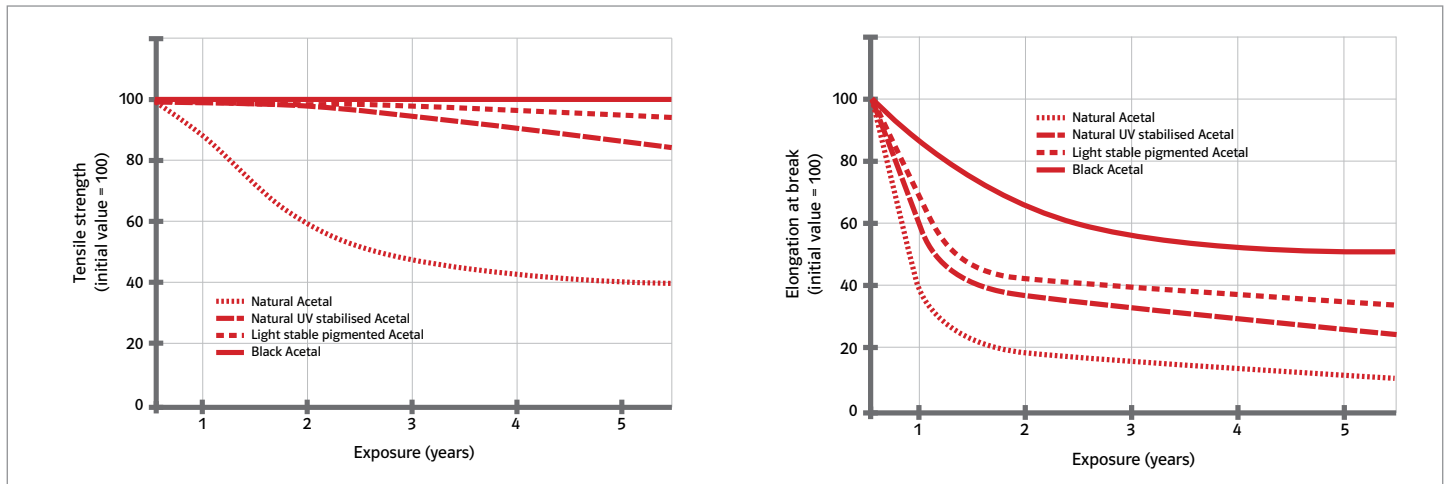

#### Accelerated Weathering Tests – Xenotest 1200 Environmental Weathering Chamber

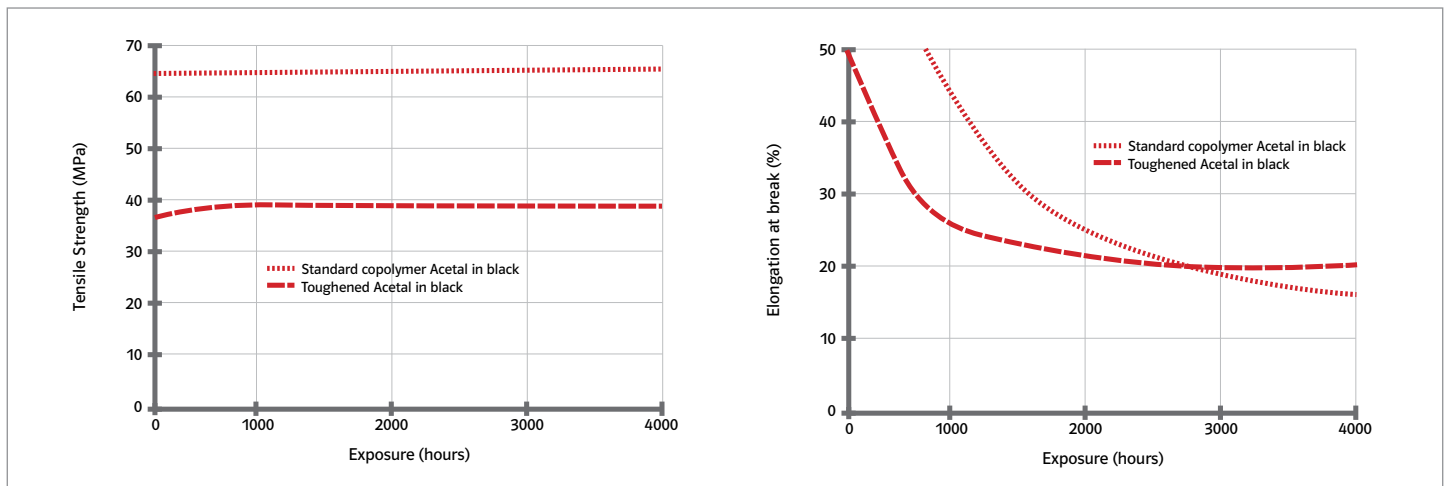

## Conclusion

- The degradation caused by weathering, in both the black and natural **POM (Acetal)** tends to reduce the Tensile strength and the Elongation at break of the material over time. This makes the polymer weaker and more brittle.
- The carbon black UV stabiliser gives a huge increase in weathering resistance to **POM (Acetal)**.

## 4.7 | Chemical Resistance

The engineering polymers used in the manufacture of HCL's Banding products are specifically chosen because of their outstanding resistance to organic and inorganic substances. They are not affected by, nor do they affect: lubricating oils, greases, aliphatic and aromatic hydrocarbons including conventional fuels. **PA11 (Nylon 11)**, **PA11GF (Nylon 11 Glass-filled)** and **POM (Acetal)** are particularly resistance to sea water, with minimal water absorption, so are highly suitable for demanding applications in the oil and gas industry.

Chemical Agent	Concentration	PA66 (Nylon 6.6)		Concentration	PA11 (Nylon 11)/PA11GF (Nylon 11 Glass-filled) Performance				Concentration	POM (Acetal) Performance			
		Temp °C	Performance		20°C (68°F)	40°C (104°F)	60°C (140°F)	90°C (194°F)		unknown °C	23°C (73.4°F)	49°C (120.2°F)	82°C (179.6°F)
<b>Mineral Acids</b>													
Boric acid	7%	24	P						100%	G			
Carbonic acid	10%	24	G						100%		G		
Chloroacetic acid	10%	24	P						100%	P			
Chlorosulphonic acid	10%	24	P						100%	P			
Chromic acid	10%	24	P	10%	P	P	P	P	10%	P			
Hydrochloric acid	2.5%	23	G	1%	G	L	P	P	20%	G			
	5%	77	P						37%	G			
	10%	25	P						100%	G			
Nitric acid	10%	23	P	10%	G	L	P	P	100%		P		
				10%	P	P	P	P	5-10%		P		
Perchloric acid	10%	24	P						100%	G			
Phosphoric acid	5%	98	P	5%	G	L	P	P	100%	P			
									100%	P			
Sulphur dioxide	100%	38	P	100%	L	P	P	P	100%	G			
Sulphuric acid	1%			1%	G	L	L	P	3%		G		
	3%			10%	G	L	L	P	30%		P		
	10%												
	30%	23	P										
Sulphurous acid	10%	23	P						100%	G			
<b>Mineral Salts</b>													
Aluminium hydroxide	10%	23	L						10%		G*		G*
	10%	52	P										
Alumina sulphate				Concentrated or boiled solutions	G	G	G	G	100%	p			
	10%	23	L										
	10%	52	P										
Ammonium carbonate	10%	23	L						100%	P			
Ammonium chloride	10%	52	P						100%	G			
Ammonium hydroxide	10%	23	G**						100%	G			
	100%	70	P**										
Ammonium sulphate				Concentrated or boiled solutions	G	G	L		100%		G		
	100%												
Antimony trichloride	10%	24	P										
Barium chloride				Concentrated or boiled solutions	G	G	G	G	100%		G		
	10%	24	P										
Barium sulphate	10%	24	G						100%			G	
Barium Sulphide	10%	24	L						100%	G			
Calcium arsenate				Concentrated or boiled solutions	G	G	G						
Calcium chloride				Concentrated or boiled solutions	G	G	G	G	100%	P			
Calcium hypochlorite	5%	60	P										
Calcium hypochlorite	Sat. Sol.	35	P						100%	P			
Calcium thiocyanate	50%		P										
Copper chloride	10%	24	P						100%	G			
Copper sulphate				Concentrated or boiled solutions	G	G	G	G	100%	P			
	10%	24	P										
Copper sulphite	10%	24	P										
Di-ammonium phosphate				Concentrated or boiled solutions		G	G	L					
Hydrogen sulphide	Sat. Sol.	23	P						100%	G			
Magnesium chloride				50%	G	G	G	G	100%		G		
Potassium carbonate									100%	G			
Potassium chloride	20%	98	G										
	90%	23	G						100%	G			
Potassium hydroxide	30%	98	L						100%	G			
Potassium nitrate				Concentrated or boiled solutions	G*	L*	P	P	100%	G			
Potassium sulphate				Concentrated or boiled solutions	G	G	G	G	100%	G			
Potassium thiocyanate	Sat. Sol.		P										
Sodium carbonate				Concentrated or boiled solutions	G	G	L	P	2%		G		
	2%	35	G						2%				G
									20%				G
Sodium chloride				Saturated	G	G	G	G	Saturated		G		
	10%	23	G	10%					10%				G*
Sodium hydroxide (Caustic Soda)				50%	G	L	P	P	1%		G		
	10%	70	P**						10%		G		G*
									10%				G*
									60%				G*
Sodium nitrate	5%	24	G						100%		G		
Sodium sulphate	90%	24	G						100%		G		

## 4.7 | Chemical Resistance

Chemical Agent	Concentration	PA66 (Nylon 6.6)		Concentration	PA11 (Nylon 11)/PA11GF (Nylon 11 Glass-filled) Performance				Concentration	POM (Acetal) Performance			
		Temp °C	Performance		20°C (68°F)	40°C (104°F)	60°C (140°F)	90°C (194°F)		unknown °C	23°C (73.4°F)	49°C (120.2°F)	82°C (179.6°F)
Sodium sulphide	90%	24	G	Concentrated or boiled solutions	G	G	L						
Sodium thiosulphate									25%		G		G
Stannic chloride	10%	24	P**						100%	G			
Stannic sulphate	10%	24	P										
Tricresyl Phosphate	100%	66	G										
Trisodic phosphate				Concentrated or boiled solutions	G	G	G	G					
Zinc chloride				Saturated	G	G	L	P	100%	G			
<b>Mineral bases</b>													
Ammonia	Sat. Sol.	-33	G	Concentrated	G	G	G	G	100%	P			
	100%	24	G										
Ammonia solution				Liquid or gas	G	G							
	10%	24	P										
Potassium carbonate				50%	G	L	P	P	100%	G			
Sodium bicarbonate	50%	24	G	50%	G	L	P	P	100%	G			
<b>Other mineral bodies</b>													
Agricultural spray solution				100%		G	G						
Bleach (sodium hypochlorite)	5%	23	L	100%	L	P	P	P	5%		P		
Bromine	100%	24	P	100%	P	P			100%	P			
Bromine water	25%	23	G**										
Carbonated water				100%	G	G	G	G	100%	G			
Chlorine	100%	23	P	100%	P	P	P	P	100%	P			
Chlorine water	Sol.	23	L										
	Sat. Sol.	23	P										
Chlorox	100%	23	G						100%	P			
Fluorine				100%	P	P	P	P	100%	P			
Hydrogen				100%	G	G	G	G					
Hydrogen peroxide	3%	23	G	100%	G	L			10%	P			
	5%	43	P						50%	P			
				100%					100%	P			
Mercury				100%	G	G	G	G	100%	G			
Ozone				100%	L	P	P	P	100%	G			
Oxygen				100%	G	G	G	P					
Potassium permanganate	5%	23	P	5%	P	P			100%	G			
Sea water				100%	G	G	G	G	100%	G			
Sulphur				100%	G	G							
Water				100%	G	G	G	G	100%		G		G**
<b>Organic bases</b>													
Aniline				Pure	L	P	P	P	Pure				G**, **
Diethanolamine				20%	G	G**	G**	L	100%	G			
Pyridine				Pure	L	P	P	P	100%	G			
Urea				100%	G	G	L	L	100%	G			
<b>Organic acids and anhydrides</b>													
Acetic acid	5%	23	P**	100%	L	P	P	P	5%		G		
									20%	G			
									80%	P			
Acetic anhydride				100%	L	P	P	P	100%	P			
Benzoic acid	10%	23	P						100%	G			
Butyric acid	10%	24	P						100%	G			
Citric acid	10%	24	P	100%	G	G	L	P	10%		G		
Formic acid		23	P	100%	G	P	P	P	100%	G			
Glycolic acid	70%		P						100%	G			
Lactic acid	10%	35	G	100%	G	G	G	L	100%	G			
Oleic acid				100%	G	G	G	L	100%		G		G
Oxalic acid				100%	G	G	L	P	Cold	G			
Picric acid				100%	L	P	P	P	100%	G			
Stearic acid				100%	G	G	G	G	100%	G			
Tartaric acid				100%	G	G	G	L	100%	G			
Uric acid				100%	G	G	G	L					
<b>Hydrocarbons</b>													
Acetylene				100%	G	G	G		100%	G			
Benzene	100%	23	G	100%	G	G**	L	L	100%		G**		
Butane				100%	G	G	G		100%	G			
Cyclohexane				100%	G	G	L		100%		G		
Decaline				100%	G	G	G	L					
FORANE® 12				100%	G	G	G						
FORANE® 22				100%	G	G	G						
Heptane									100%		G		G
Hexadecane	10%	23	G**										
Methane				100%	G	G	G		100%	G			
Naphthalene				100%	G	G	G	L			G		
NUJOL	100%	70	G						100%		G		G
Propane				100%	G	G	G		Liquidified	G			
Styrene				100%	G	G**			100%	G			
Toluene	100%	50	G	100%	G	G**	L	L	100%		G		G**
Xylene	100%		G	100%	G	G**	L	L	100%	G			
<b>Alcohols</b>													
Benzyl alcohol				100%	L	P	P	P					
Butanol	100%	50	G	100%	G	G	G		100%	G			
Ethanol	100%	23	G**	100%	G	G	G		100%		G		G**
	100%	50	G**										
Ethylene glycol	50%	23	G						50%				P
Glycerin				100%	G	G	G		100%	G			
Glycol				100%	G	G	G	P					

## 4.7 | Chemical Resistance

Chemical Agent	Concentration	PA66 (Nylon 6.6)		Concentration	PA11 (Nylon 11)/PA11GF (Nylon 11 Glass-filled) Performance				Concentration	POM (Acetal) Performance			
		Temp °C	Performance		20°C (68°F)	40°C (104°F)	60°C (140°F)	90°C (194°F)		unknown °C	23°C (73.4°F)	49°C (120.2°F)	82°C (179.6°F)
Methanol	100%	23	G**	100%	G	G	G		100%	G			
<b>Aldehydes and ketones</b>													
Acetone	100%	23	G	100%	G	G**	L	P	100%		G**		
	100%	50	G										
Acetaldehyde	100%	52	L	100%	G	L	P						
Formaldehyde	38%	23	G	100%	G	L	P		40%			G	
				100%					100%	G			
Cyclohexanone				100%	G	L	P						
Methyl ethyl ketone				100%	G	G	L	P	100%	G			
Methyl isobutyl ketone	100%	23	G	100%	G	G	L	P					
Benzaldehyde				100%	G	L	P		100%	G			
<b>Chlorinated solvents</b>													
AROCOLOR 1242	100%	23	G										
Carbon tetrachloride	100%	23	G	100%	P				100%		G	G**	
	100%	50	G										
Dichloroethane	100%	66	G						100%			G**	
Hexafluoroisopropanol	100%	23	P										
Methyl bromide				100%	G	P			100%	P			
Methyl chloride	100%	23	L	100%	G	P			100%	G			
Methyl trichloride	100%	23	G										
Methylene chloride	100%	23	L						100%	G			
Tetrafluoropropane													
Trichloroethylene				100%	L	P			100%	P			
Trichloroethane	100%	72	G	100%	L	P	P	P	100%	G			
Perchloroethylene				100%	L	P			100%	G			
Phenols	5%	23	P	100%	P	P	P	P	5%		G**		
<b>Various organic bodies</b>													
Anethol				100%	G								
Carbon sulphide				100%	G**	L*	P						
Dibromoethane	100%	50	L										
Dimethyl formamide									100%	P			
Ethylene oxide				100%	G	G	L	P	100%	P			
Furfural				100%	G	G**	L	P	100%	G			
Glucose				100%	G	G	G	G	100%	G			
Glycol chlorhydrine				100%	P	P							
Nitromethane	100%	23	G						100%	G			
2-Nitropropane	100%	72	G										
Tetraethyl lead				100%	G								
<b>Salts, esters, ethers</b>													
Amyl acetate	100%	98	P	100%	G	G	G	L	100%		G		
Butyl acetate				100%	G	G	G	L	100%	G			
Diethylene glycol	90%	24	G						100%		G		
Dimethyl ether									100%		G**		
Diethyl phosphate				100%	G	G	G	L					
Diethyl phthalate				100%	G	G	G						
Ethyl acetate	100%	50	G	100%	G	G	G		100%		G**	G**	
Fatty acid esters				100%	G	G	G	G	100%	G			
Methyl acetate				100%	G	G	G		100%	G			
Methyl sulphate				100%	G	L							
Sulphuric ether				100%	G								
Tributyl phosphate				100%	G	G	G	L					
Tricresyl phosphate	100%	66	G	100%	G	G	G	L		G			
<b>Miscellaneous products</b>													
Antifreeze	100%	104	L						100%				P
Automatic transmission fluid									100%				G
Beer				100%	G				100%		G		
Brake Fluid											G		G**
Cider				100%	G				100%	G			
Coal gas				100%	G	G							
Crude oil				100%	G	G	G**						
Detergent									100%				G*
Diesel									100%			G**	
Fruit juice				100%	G	G							
Gasohol									100%		G	G	
Grease				100%	G	G	G	G	100%				G
Kerosene				100%	G	G	G**		100%				G
Lanolin suspension	10%	35	G										
2,4-D Lindane				100%	G								
Linseed Cake	100%	82	G		G	G	G	G	100%				G
Milk				100%	G	G	G	G	100%	G			
Motor oil									100%				G
Mustard				100%	G				100%	G			
Naphtha	100%	98	G**	100%	G	G	G**		100%		G		
Oil				100%	G	G	G	G					
Oxyquinoline (agricultural spray)				100%	G								
Premium grade gasoline				100%	G	G	G**		100%			G**	
Regular grade gasoline				100%	G	G	G**		100%			G**	
Soap Cleanser				100%	G				100%				G**
Stearine				100%	G	G	G						
Turpentine				100%	G	G	G**		100%			G	
Vinegar				100%	G				100%	G			
Wine				100%	G								

\*Discolouration occurs. \*\*Swelling action. G = Good. L = Limited. P = Poor.



## 5.1 | Quality Policy

Within HCL Fasteners Ltd we are committed to provide products and services which meet the customers' specified contractual and project requirements and those of all applicable regulating authorities.

We are totally committed to setting and achieving quality standards that are capable of meeting, in all respects, the specified requirements and reasonable expectations of our customers, whilst working within the framework of statutory, regulatory and legal requirements.

In order to achieve this objective, it is the policy of HCL Fasteners to maintain an effective quality system based on the requirements of: **BS EN ISO 9001-2008**.



## Goods Received Inspection

HCL's banding products are manufactured to the highest standard using the latest equipment and techniques. The injection-moulding and extrusion machines are computer controlled and the settings for each mould tool are recorded for maximum repeatability. Before a production run can begin, the first-off components must be checked and approved against their specification. The machines also have quality control capabilities where parameters, e.g. melt cushion, are given an acceptable tolerance range. If these parameters go out of tolerance, a quality flap automatically rejects the parts.

## Injection Moulding & Extrusion Control

HCL's banding products are made from polymers that are inspected on receipt from our suppliers, by the quality controller. The material is inspected for:

- Quality
- Type
- Satisfactory packaging

The Goods Inwards inspection information is logged and retained by the Quality Control Department. If the material passes this inspection satisfactorily, it is transferred to raw material stores.

## Statistical Process Control

SPC data relating to each manufacturing batch is available to customers upon request. This data is entered into a computer for dimensional verification and weight checks. The SPC sample

and a hard copy of the SPC data are stored for reference and product traceability.

First and Last off samples for each batch are tested using a calibrated Zwick Tensile testing machine, to ensure that they meet the required performance.

## Routine Production Checks

Products found to be outside specification are rejected, and the batch concerned isolated. Settings are adjusted until satisfactory yield is achieved and the suspect batch subject to 100% inspection.

## Final Inspection

All products are given a final visual and physical inspection. During packaging, quality is confirmed by:

- An inspection ticket packed with the goods.
- A Quality Assurance label attached to the outside of the packaging.

If required, a certificate of conformity to HCL's product specification can be issued.

## Quality Policy

HCL is committed to the highest possible quality standards. Quality control systems are subject to review at appropriate intervals in consideration of the following:

- Changes in technology
- Changes to markets
- Changes in legislation
- External assessor's reports
- Overall company facilities & policies

**Your attention is drawn to the following:**

The statements, technical information and recommendations contained herein are believed to be accurate as of the date hereof. Since the conditions and methods of use of the product and of the information referred to herein are beyond our control, HCL expressly disclaims any and all liability as to any results obtained or arising from any use of the product or reliance on such information; NO WARRANTY OF FITNESS FOR ANY PARTICULAR PURPOSE, WARRANTY OR MERCHANTABILITY OR ANY OTHER WARRANTY, EXPRESS OR IMPLIED, IS MADE CONCERNING THE GOODS DESCRIBED OR THE INFORMATION PROVIDED HEREIN. The information provided herein relates only to the specific product designated and may not be applicable when such product is used in combination with other materials or in any process. The user should thoroughly test any application before commercialization. Nothing contained herein constitutes a license to practice under any patent and it should not be construed as an inducement to infringe any patent and the user is advised to take appropriate steps to be sure that any proposed use of the product will not result in patent infringement.

The information contained in this document is based on trials carried out in our internal laboratory and data selected from the literature, but shall in no event be held to constitute or imply any warranty, undertaking, express or implied commitment from our part. Our formal specifications define the limit of our commitment. No liability whatsoever can be accepted by HCL with regard to the handling, or use of the product or products concerned which must in all cases be employed in accordance with all relevant laws and/or regulations in force in the country or countries concerned.



**HCL – UK & Rest of the World**

Tel: +44 (0)1761 417714

Fax: +44 (0)1761 417710

Email: [sales@hcl-clamping.co.uk](mailto:sales@hcl-clamping.co.uk)

**HCL – North America**

Tel: 281-717-1145

Fax: 281-717-1146

Email: [sales@hcl-clamping.com](mailto:sales@hcl-clamping.com)

Visit [www.hclfasteners.com](http://www.hclfasteners.com) to view our complete range of products.



©2012 HCL Fasteners. All Rights Reserved.